



# VMD460-NA

## Network and system protection (NS protection) for monitoring the network feed-in from generating plants

Software version, measurement technology: D398 V1.4x

Software version, display: D403 V2.4x



## VMD460-NA

This quick-start guide does not replace the manual!

Quick-start guide for the following devices

Type	Supply voltage $U_s$	Art. No.	Manual No.
VMD460-NA-D-2	AC/DC 100 ... 240 V/ DC 50/60 Hz	B93010045	D00001
Mounting clip for screw mounting		B98060008	—

### Scope of delivery

- VMD460-NA
- Safety instructions
- Quick-start



Manual

### Intended use

The VMD460-NA voltage and frequency monitoring relay is used for network and system protection (NS protection) of CHP plants, wind power stations, hydroelectric power stations and photovoltaic systems feeding power into the network. If inadmissible voltage and frequency values occur on the supply side, the VMD460-NA disconnects the generating plant from the public network by means of an interface switch.

In order to meet the requirements of the applicable standards, adaptation to the system and operating conditions must be carried out on site. Please heed the limits of the area of application indicated in the technical specifications.

Any other use than that described in this document is regarded as improper.

### Safety instruction



**DANGER! Danger of electric shock.** Touching live parts of the system carries the risk of:

- An electric shock
- Damage to the electrical installation
- Destruction of the device

Before installing and connecting the device, make sure that the installation has been de-energised.

The rules for working on electrical systems must be observed.

The standards and regulations of the respective location apply.

### Dimensions

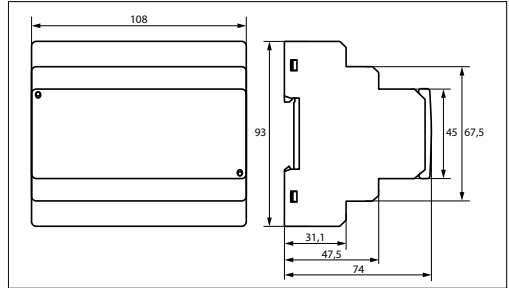

All dimensions in mm

### Installation

DIN rail (schematic diagram)

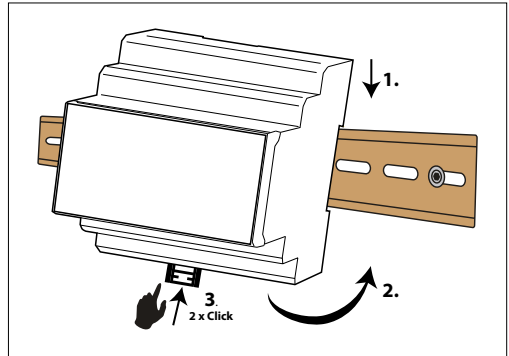

### Screw mounting

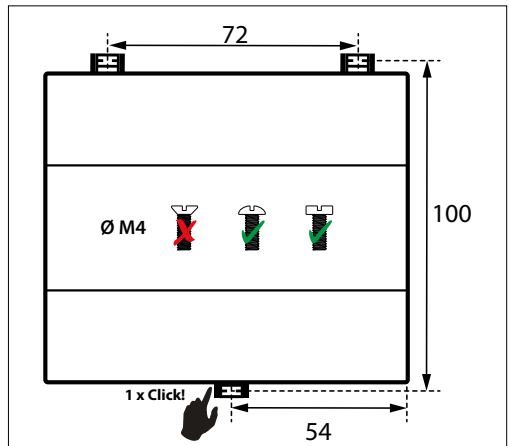

## Connections

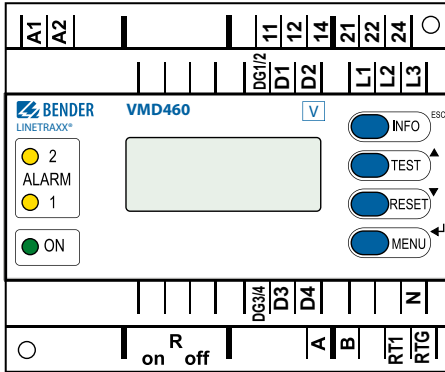

A1, A2	Supply voltage $U_s$
L1, L2, L3, N	Power supply connection
K1, K2	Relay connections
DG1/2, D1, D2	Contact monitoring interface switch DG1/2: GND D1: Feedback signal contact K1 D2: Feedback signal contact K2
RTG, RT1	RTG: GND RT1: remote trip input
A, B	Service interface
Ron/off	Terminating resistor of the service interface (120 $\Omega$ )
DG3/4, D3, D4	Digital inputs

## Application standards

Standard/application guide	Name on the display
VDE-AR-N 4105:2018-09	4105_2
VDE-AR-N 4105:2011-08	4105_1
VDE-AR-N 4110:2018-11	4110
BDEW technical guideline 2008 with amendments until 01.2013	BDEW
DIN V VDE V 0126-1-1:2006-02/A1:2012-02	0126
CEI 0-21(:2012-06, :V1:2012-12, :V2:2013-12, :2014-09, :V1:2014-12)	CEI 021
C10/11:2012-06	C10/11
G98:2018-05	G98
G83/2:2012 and G59/3:2013	G83/2
G99:2018-05	G99
G59/2(:2010, -1:2011)	G59/2

## Wiring diagram VDE-AR-N 4105:2018 – basic program 4105\_2,

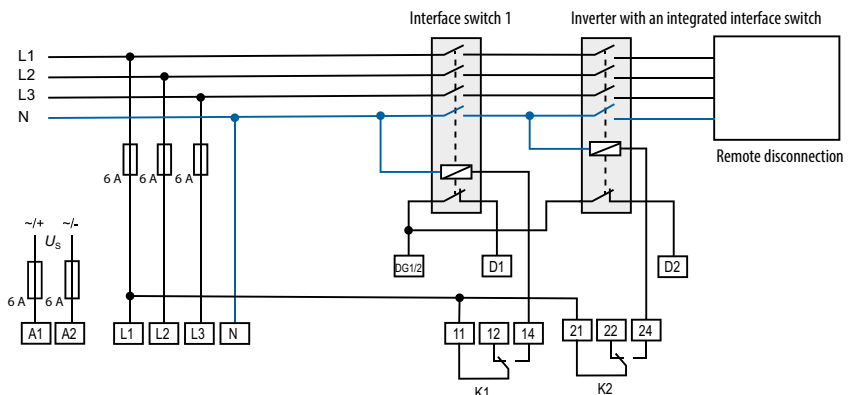

**Wiring diagram VDE-AR-N 4110:2018-11 – basic program 4110 (suggestion)**

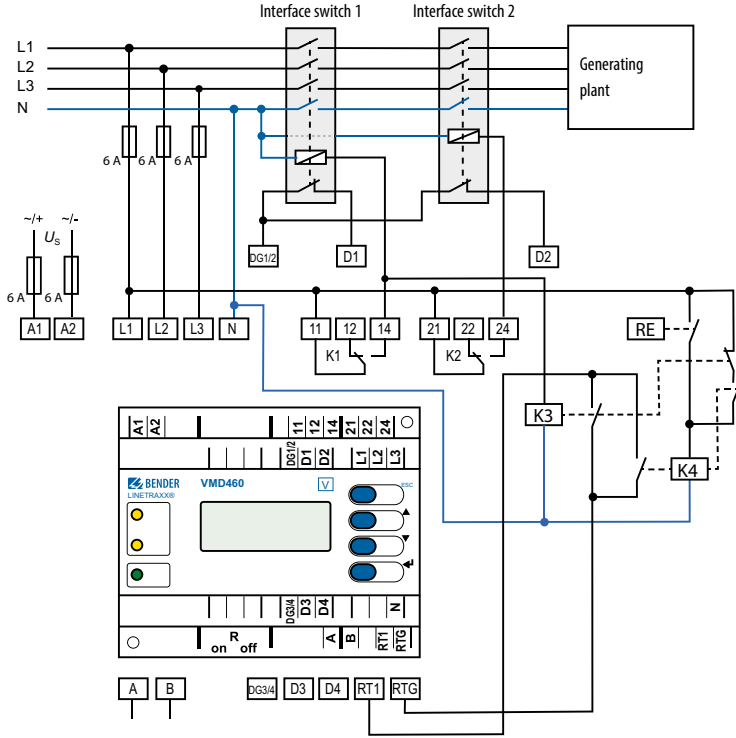

**Wiring diagram EREC G99, G98, C10/11, DIN V VDE V 0126-1-1  
basic programs G98, G99, C10/10, 01261**

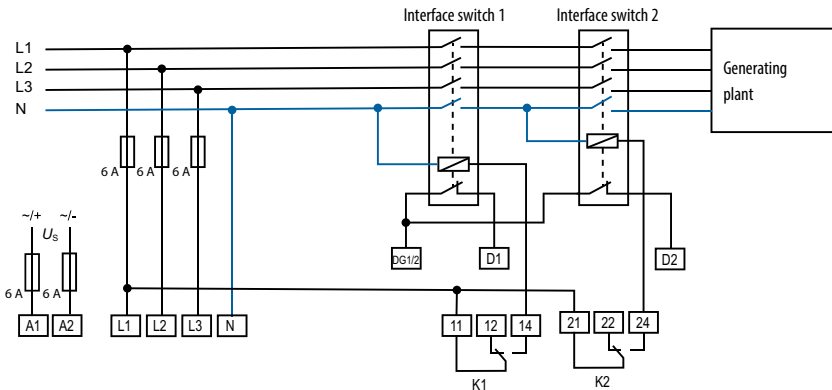

Further wiring diagrams in the manual.

## Operating elements

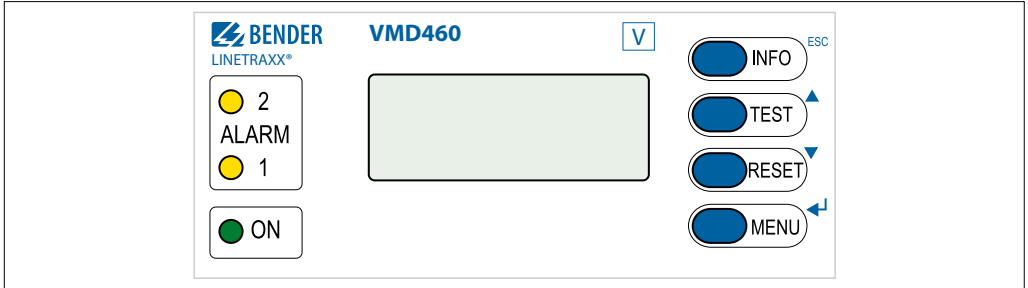

Element	Function
ON	<b>Power On LED (green):</b> lights when the voltage supply is available and the device is in operation; flashes when the device is being started or when an internal device error has occurred
ALARM1 ALARM2	System disconnected: <b>Both LEDs light (yellow):</b> In case of a limit value violation of voltage or frequency, remote disconnection (remote trip, optional), df/dt (optional), vector shift detection (optional), unbalance (optional); <b>Both LEDs flash (yellow):</b> In case of an internal device error or contact monitoring error <b>Only ALARM 1 lights:</b> Reconnection conditions met. t(ON) elapses
	Backlit LC display
INFO	<b>Standard display:</b> Measured value display and device information <b>Menu display:</b> Exit the parameter setting menu without saving; Go to the next higher menu level
TEST	<b>Standard display:</b> The TEST button (> 1.5 s) is used to start a manual self test which triggers both output relays (tripping test to check the interface switches). In addition, the disconnection times are documented. <b>Menu display:</b> Arrow-up button for parameter change and scrolling
RESET	<b>Standard display:</b> (> 1.5 s) Acknowledge error messages from contact monitoring <b>Menu display:</b> Arrow-down button for parameter change and scrolling
MENU	<b>Standard display:</b> Toggle between standard, menu and alarm display <b>Menu display:</b> Go to setting parameters; save changes

## Navigation

Button	Navigation	Function
INFO	ESC	Jump back one menu level
TEST	▲	Menu item selection (previous); parameter selection (previous) Value increase
RESET	▼	Menu item selection (next); parameter selection (next) Value decrease
MENU	⏏	Confirm entered value

## Menu structure (MENU)

Alarm/meas.values	U(1-N); U(2-N); U(3-N); U10LN; U10LL; U(1-2); U(2-3); U(3-1); frequency; df/dt; state; $t_{(ON)}$ ; unbalance; vect.shift**; rotating field; $t_{(OFF)}$ TOTAL; $t_{(OFF)}$ DEVICE		Specification of the parameter and the corresponding VALUE in each case See manual, chapter 5.4.2
History	Line 1: Event number Line 2: Start of the event: Date/time Line 3: Acknowledgement of the event: Date/time Line 4: End of the event: Date/time		See manual, chapter 5.4.3
Settings	The menu structures in the settings contain different entries for each standard.		See manual, chapter 6
System	History Language Clock Password Interface Alarm addresses TEST RESET Test communication External devices Factory settings	Clear history English/Deutsch/Italiano Format/date/time/summer time Password/state Address; master 1...90; slave 2...90 Address 1...150 Run TEST Perform RESET 1...12. channel List of connected devices Restore factory settings	See manual, chapter 5.4.4
Info	Device name Current date and time BMS bus address Software version, measurement technology Software date, measurement technology Software version, display Software date, display Manufacturer of the device Address of the manufacturer Internet address of the manufacturer		See manual, chapter 5.4.5

## Commissioning steps

1	Select a language (English, German, Italian)	<b>Menu 4.2 :</b> 4. SYSTEM → 2. Language
2	Set date and time additionally.	<b>Menu 4.3 :</b> 4. SYSTEM → 3. Clock
3	Select a standard.	<b>Menu 3.1.1 :</b> 3. SETTINGS → 1. General → 1. Standard

After commissioning, the parameters of the VMD460-NA can be changed.



**Unauthorised changes.** After commissioning, the essential settings of the VMD460-NA have to be protected against unauthorised changes by a password. If the password protection is not used, the device has to be sealed.

**Display contrast.** Simultaneously press and hold down the buttons "INFO" and "MENU" until the display text is clearly readable.

**Change of standard.** Existing user-defined settings are not saved when the user standard is changed.

## Technical data

### Insulation coordination acc. to IEC 60664-1/IEC 60664-3

Rated voltage.....	400 V
Rated impulse voltage.....	6 kV
Pollution degree.....	2
Overvoltage category.....	III
Voltage test according to IEC 61010-1: (N, L1, L2, L3) - (A1, A2), (11, 12, 14, 21, 22, 24).....	3.32 kV

### Supply voltage

Nominal supply voltage $U_s$ .....	AC/DC 100...240 V; ..... DC/50/60 Hz
Operating range $U_s$ .....	AC/DC 75...300 V ..... DC/40...70 Hz
Power consumption at AC 230 V.....	< 7.5 VA/< 3.5 W ..... max. 9 VA/3.5 W

### Measuring circuit

System type.....	1AC: 230 V, 50 Hz ..... 3(N)AC: 400/230 V, 50 Hz
Nominal system voltage $U_n$ (r.m.s. value) (L-N).....	AC 0...300 V
Nominal system voltage $U_n$ (r.m.s. value) (L-L).....	AC 0...520 V
Input resistance (Load) L1, L2, N.....	480 kΩ
Input resistance (Load) L3.....	680 kΩ
Rated frequency $f_n$ ( $U_n > 20$ V).....	45...65 Hz
Response values.....	1...150%
Relative uncertainty, voltage.....	$U \leq 280$ V: $\pm 1\%$ ..... $U > 280$ V: $\pm 3\%$
Resolution of setting, voltage.....	1 %
Nominal frequency.....	50/60 Hz
Relative uncertainty, frequency.....	$\pm 0.1\%$
Resolution of setting $f$ .....	0.05 Hz

### Time response

Delay time for connection $t_{on}$ .....	40 ms...60 min
--	----------------

### Digital inputs

Monitoring of potential-free contacts or voltage inputs:.....	closed = low; 0...4 V; $I_{in} < -5$ mA ..... open = high; 6...30 V
D1.....	feedback signal contact K1
D2.....	feedback signal contact K2
D3.....	local control (mode)
D4.....	external signal (mode)
RT1.....	remote trip
DG1/2, DG3/4, RTG.....	GND
Max. length of the connecting cables of digital inputs.....	3 m

### Displays, memory

Display.....	LC display, multi-functional, illuminated
Display range, measured value.....	AC/DC 0...520 V
Operating uncertainty, voltage.....	$U \leq 280$ V: $\pm 1\%$ ..... $U > 280$ V: $\pm 3\%$
Operating uncertainty, frequency.....	$\pm 0.1\%$

### Switching elements

Number of changeover contacts.....	2 x 1 (K1, K2)
Operating mode.....	NC operation/NO operation.

### Environment/EMC

EMC.....	DIN EN 60255-26/CEI 0-21
Operating temperature.....	-25...+55 °C

### Classification of climatic conditions acc. to IEC 60721

(except condensation and formation of ice)	
Stationary use (IEC 60721-3-3).....	3K23
Transport (IEC 60721-3-2).....	2K11
Long-term storage (IEC 60721-3-1).....	1K22

### Classification of mechanical conditions acc. to IEC 60721

Stationary use (IEC 60721-3-3).....	3M11
Transport (IEC 60721-3-2).....	2M4
Long-term storage (IEC 60721-3-1).....	1M12

### Connection

Connection type.....	screw-type terminals or push-wire terminals
Connection properties:	
rigid.....	0.2...4 mm <sup>2</sup> (AWG 24...12)
flexible.....	0.2...2.5 mm <sup>2</sup> (AWG 24...14)
Stripping length.....	8...9 mm
Tightening torque.....	0.5...0.6 Nm

### Other

Operating mode.....	continuous operation
Mounting.....	any position
Degree of protection, internal components (DIN EN 60529).....	IP30
Degree of protection, terminals (DIN EN 60529).....	IP20
Flammability class.....	UL94 V-0
DIN rail mounting acc. to.....	IEC 60715
Screw mounting.....	2 x M4 with mounting clip
Documentation number.....	D00001

( )\* = Factory setting

---

## EU Declaration of Conformity

The full text of the EU Declaration of Conformity is available via the QR Code:



## UKCA Declaration of Conformity

The full text of the UK Declaration of Conformity is available via the QR Code:



**Bender GmbH & Co. KG**

Londorfer Straße 65  
35305 Grünberg  
Germany

Tel.: +49 6401 807-0  
info@bender.de  
www.bender.de

Alle Rechte vorbehalten.  
Nachdruck und Vervielfältigung nur mit  
Genehmigung des Herausgebers.

All rights reserved.  
Reprinting and duplicating only with  
permission of the publisher.



© Bender GmbH & Co. KG, Germany  
Subject to change! The specified  
standards take into account the edition  
valid until 04/2024 unless otherwise  
indicated.