

This document is intended as a reference guide for installing and using a BENDER GM420 ground continuity monitor. This document includes installation, setup, and usage instructions. For complete details, including installation, setup, settings, and troubleshooting, refer to the GM420 user manual, document number TGH1413en. This document is intended as a supplement and not a replacement to the complete user manual.

Only qualified maintenance personnel shall operate or service this equipment. These instructions should not be viewed as sufficient for those who are not otherwise qualified to operate or service this equipment. This document is intended to provide accurate information only. No responsibility is assumed by BENDER for any consequences arising from use of this document.



## Installation

### Mounting

GM420 series devices may be DIN rail mounted, or screw mounted using the black clips located on the top and bottom of the device. Screw mounting requires an extra black clip (article number B98060008, sold separately).

### Wiring - General

The example below shows the GM420 used for monitoring the ground connection of a motor. Use may vary. The GM420 monitors the ground connection by connecting via pilot wires to create a loop. The GM420 then monitors the resistance of this loop, as well as checking for any extraneous voltage between the two ground connections. Refer to figure 1 for wiring the GM420. Use minimum AWG 24, maximum AWG 12 size wire. Refer to GM420 series user manual for complete technical details.

⚠ **DANGER**

HAZARD OF ELECTRIC SHOCK,  
EXPLOSION, OR ARC FLASH

- Disconnect all power before servicing.
- Observe all local, state, and national codes, standards, and regulations.

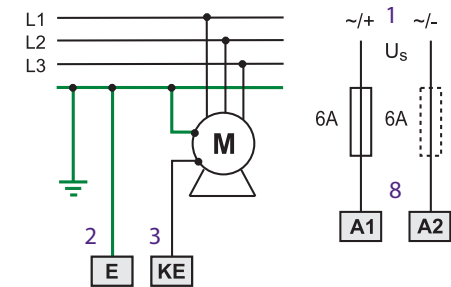

1. External supply voltage
2. Ground connection
3. Pilot wire connection to ground / clamp / load grounding point
4. Alarm relay K1: SPDT contact
5. Alarm relay K2: SPDT contact
6. Test button
7. Reset button
8. Recommended fusing for line protection

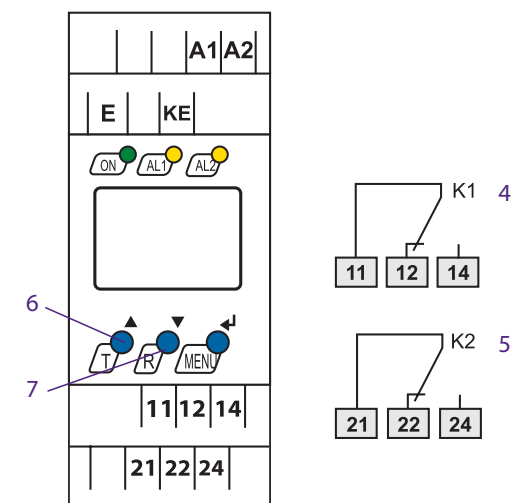

Figure 1 - GM420 wiring diagram

### Wiring - Contacts

Using a normally closed or normally open contact utilizes two factors: wiring out of the proper terminal, and setting the respective contact to normally energized or deenergized operation. Refer to the chart below for relay conditions. For changing the energized state of the contact, refer to "Figure 7 - Contact operation" on the reverse side of this document.

The factory default for the GM420 is normally energized operation for relay K2, and normally deenergized operation for relay K1.

Device Relay Conditions			
Relay Operation Setting	Device Alarm State	K1 STATE	K2 STATE
Normally deenergized mode (N/D) Non-failsafe mode "N/O" in device settings menu	Power ON, normal state (no alarms)	11-12 CLOSED 11-14 OPEN	21-22 CLOSED 21-24 OPEN
	Power OFF	11-12 CLOSED 11-14 OPEN	21-22 CLOSED 21-24 OPEN
Energized in the alarm state Relay will switch when the alarm is activated.	Power ON, alarm state	11-12 OPEN 11-14 CLOSED	21-22 OPEN 21-24 CLOSED
	Power OFF	11-12 CLOSED 11-14 OPEN	21-22 CLOSED 21-24 OPEN
Normally energized mode (N/E) Failsafe mode "N/C" in device settings menu	Power ON, normal state (no alarms)	11-12 OPEN 11-14 CLOSED	21-22 OPEN 21-24 CLOSED
	Power OFF	11-12 CLOSED 11-14 OPEN	21-22 CLOSED 21-24 OPEN
Energized in the normal state Relay will switch when the alarm is activated, or when supply voltage to the device is lost.	Power ON, alarm state	11-12 CLOSED 11-14 OPEN	21-22 CLOSED 21-24 OPEN
	Power ON, alarm state	11-12 CLOSED 11-14 OPEN	21-22 CLOSED 21-24 OPEN

## Front Panel Display

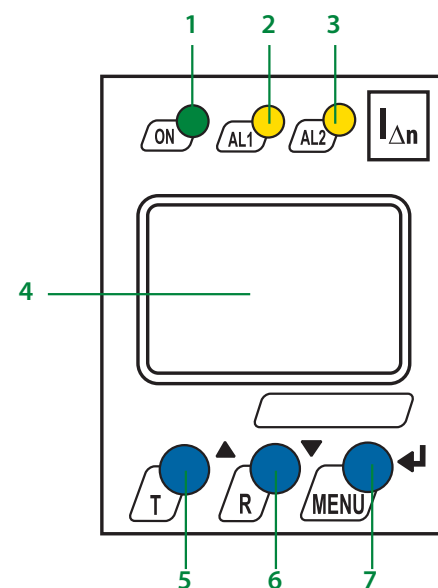
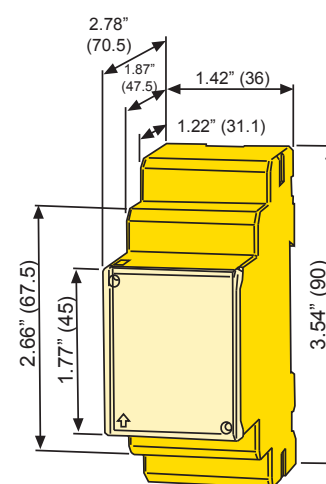

Figure 2 - GM420 front display

1. LED "ON" (green): Illuminates when power is applied to the device. Flashes when the CT connection alarm is active.
2. LED "AL1" (yellow): Illuminates when the prealarm is activated. Flashes when the CT connection alarm is active.
3. LED "AL2" (yellow): Illuminates when the main alarm is activated. Flashes when the CT connection alarm is active.
4. Backlit LCD display
5. TEST / UP button: Activates self-test / scrolls up inside main menu.
6. RESET / DOWN button: Resets device / scrolls down inside main menu.
7. MENU / ENTER button: Activates main menu / Confirms (momentary push) or goes back a step (held > 1.5 s) inside main menu.

## Dimensions



Dimensions in inches (mm).



## Menu Flow Chart for Common Settings

Figure 4 through figure 8 on the reverse side of this document contain flow charts for modifying commonly used features and settings in the GM420's main menu. Not all available features are listed in this document. For more information, consult the GM420 user manual.

## Menu Legend

-  DOWN ARROW button      < 1.5 s      Momentary button push
-  UP ARROW button      > 1.5 s      Hold button for at least 1.5 s, then release
-  MENU / ENTER button

