

CMD420 / CMD421 Series

Digital Current Relay (Overcurrent and Undercurrent)
For Three-Phase AC Systems





CMD421

Features

- Undercurrent and/or overcurrent monitoring in three-phase AC systems
- Current transformer ratio entered into device; primary values displayed in real-time on LCD display
- Overcurrent mode: 2 separate alarms
- Undercurrent mode: 2 separate alarms
- Window mode: High and low alarms
- Start-up delay, response delay, delay on release
- Adjustable switching hysteresis
- True RMS value measurement (AC)
- Digital LCD display with real-time readings and onboard menu
- LEDs: Power On, Alarm 1, Alarm 2
- Memory stores last alarm value
- Non-volatile memory for settings
- Continuous self monitoring
- Internal test/rest button
- Two separate SPDT alarm relays
- Normally energized or normally de-energized operation
- Latching or non-latching operation
- Password protection for device setting
- Sealable transparent cover
- RoHS compliant

CMD420

- 0 - 1 A alarm setpoint (at ratio $n = 1$)
- Utilizes three separate 1 A secondary current transformers (x/1 type, up to 2000:1)

CMD421

- 0 - 5 A alarm setpoint (at ratio $n = 1$)
- Utilizes three separate 5 A secondary current transformers (x/5 type, up to 2000:5)

Description

CMD420 and CMD421 series relays monitor for overcurrent and/or undercurrent in three-phase AC systems. Current is measured as true RMS values. Values are shown in real-time on the device's LCD display. The current on each phase may be displayed independently by pressing the UP or DOWN buttons on the device. Each alarm type may be independently activated or deactivated based on the system requirements. Three separate time delays (startup delay, alarm response delay, and delay on release) allow the CMD420 / CMD421 to be tailored to specific applications. Two SPDT alarm contacts may be assigned individual alarms.

Measurements are obtained via connected current transformers, one per phase. The CMD420/CMD421 may be set to alarm from 0 to 1 A and uses current transformers with a 1 A secondary (x/1 type, up to 2000:1). The CMD421 may be set to alarm from 0 to 5 A and uses current transformers with a 5 A secondary (x/5 type, up to 2000:5). Transformer ratios should be selected based on the load current monitored.

Alarm values are entered into the device based on the secondary rating of the current transformer. The ratio of the current transformers used is entered into the device's on-board menu. Doing so displays the current on the primary side of the current transformer during real-time operation - no mental calculations required.

CMD420 and CMD421 devices utilize an external supply voltage for power. Consult table "Ordering Information" on available supply voltage ranges.

Typical applications

- Three-phase AC systems
- Three-phase motors, pumps, and other industrial equipment
- General three-phase distribution networks / equipment requiring current monitoring

Function

Once the supply voltage is applied, the startup delay "t" is activated. Measured current that may cause an alarm will not activate until after the startup delay is complete.

Each type of alarm may be assigned an individual value. Two separate alarm states ("R1" and "R2") may then be assigned any combination of these alarms to trip their respective contacts. When any alarm has been activated, the response delay "t_{on1/2}" will activate. Once the response delay has elapsed, if the alarm is still active, the appropriate contact will trip and the alarm LEDs light. Once the alarm has cleared, the delay on release "t_{off}" begins. Once this delay has elapsed and the alarm is still cleared, the appropriate contact will switch back.

If the device is set to operate in latching mode ("fault memory"), the device must be manually reset if it goes into alarm. If it is set to non-latching mode, the alarm will automatically clear itself. Regardless of this setting, the last alarm value will be stored in the device's onboard history. Device settings are stored in non-volatile memory and will remain set even with a loss of supply voltage.

Approvals





Front display

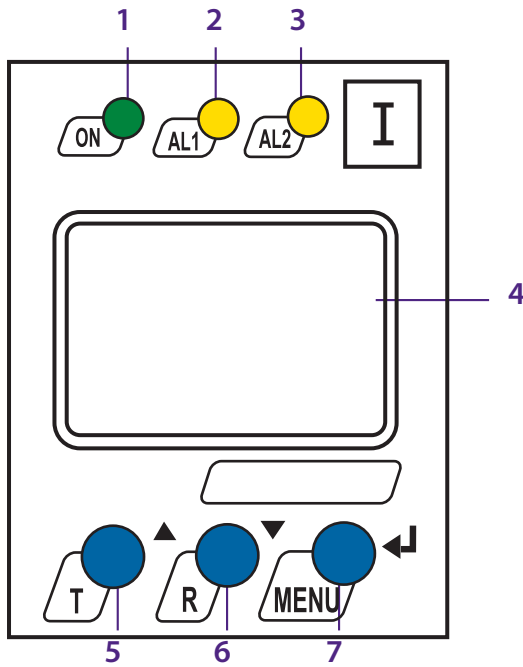

- 1 - Power On LED "ON" (green), lights when supply voltage is applied and flashes in the event of system fault alarm.
- 2 - Alarm LED "AL1" (yellow): lights when the set response value is exceeded and flashes in the event of system fault alarm.
- 3 - Alarm LED "AL2" (yellow): lights when the value falls below the set response value and flashes in the event of system fault alarm.
- 4 - Multi-functional LCD display
- 5 - Test button "T": UP key: Change displayed value, move downwards in the menu or change parameters. Holding for > 1.5 s initiates a self-test.
- 6 - Reset "R" button: DOWN key: Change displayed value, move downwards in the menu or change parameters. Holding for > 1.5s resets the device.
- 7 - MENU key: Enter key: Confirms / changes parameters. When on the main screen, holding for > 1.5 s enters the main menu. When in the menu, holding for > 1.5 s cancels an action or moves back a step in the menu structure.

Wiring diagram

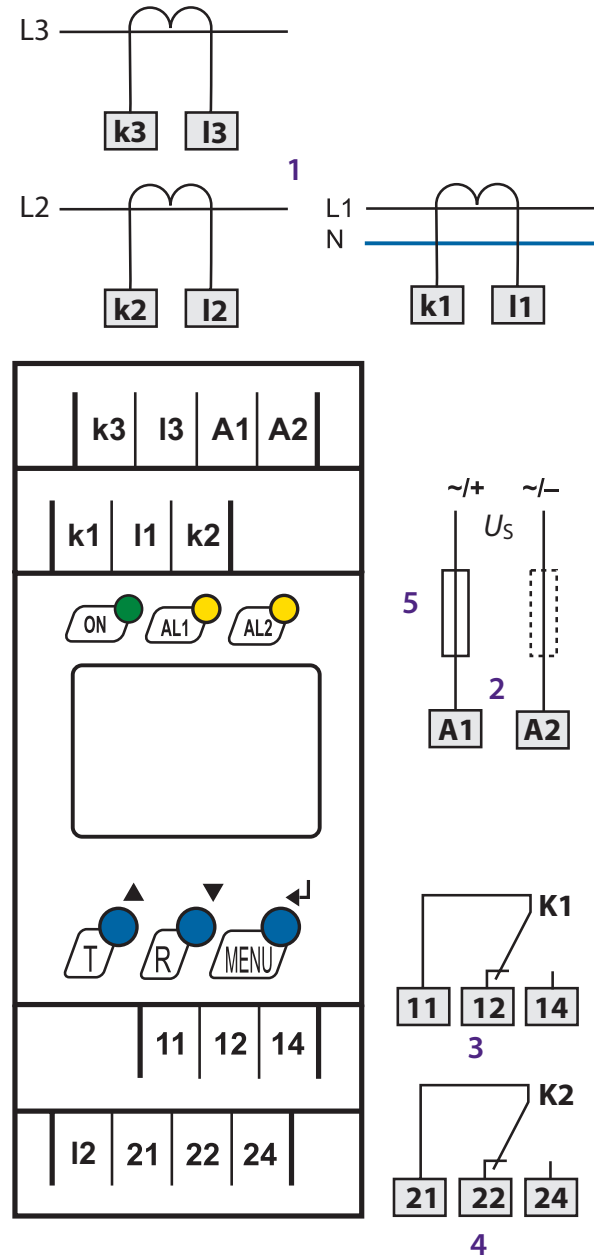

- 1 - Connection to individual conductors via current transformers
- 2 - Supply voltage U_s (see ordering information)
- 3 - Alarm relay K1: Configurable for all available alarms
- 4 - Alarm relay K2: Configurable for all available alarms
- 5 - 5 A supply voltage fusing required

Ordering information

| Type | Supply voltage U_5^* | Response value | Supported CT type | Ordering No. |
|------------|---|----------------|----------------------------------|--------------|
| CMD420-D-1 | DC 9.6...94 V / AC 42...460 Hz 16...72 V | 0... 1 A | 1 A secondary (x/1) up to 2000:1 | B 9306 0006 |
| CMD420-D-2 | DC 70...300 V / AC 42...460 Hz 70...300 V | 0... 1 A | 1 A secondary (x/1) up to 2000:1 | B 9306 0007 |
| CMD421-D-1 | DC 9.6...94 V / AC 42...460 Hz 16...72 V | 0... 5 A | 5 A secondary (x/5) up to 2000:5 | B 9306 0008 |
| CMD421-D-2 | DC 70...300 V / AC 42...460 Hz 70...300 V | 0... 5 A | 5 A secondary (x/5) up to 2000:5 | B 9306 0009 |

* absolute values

Dimensions

Dimensions in inches (mm)

Open the front plate cover in direction of arrow.

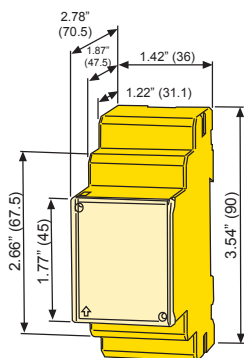

Screw fixing

Note: Additional clip required for screw mounting (See ordering information).

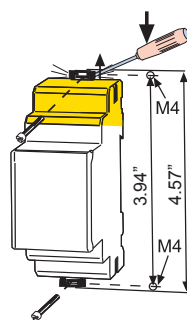

Accessories

| Type | Ord. No. |
|--|-------------|
| Clip for screw mounting (Qty. 1 req'd) | B 9806 0008 |

Technical data

Insulation coordination acc. to IEC 60664-1 / IEC 60664-3

| | |
|---|--|
| Rated insulation voltage | AC 250 V |
| Rated impulse voltage/pollution degree | 6 kV / III |
| Protective separation (reinforced insulation) between | (A1, A2) - (k, l) - (11, 12, 14) - (21, 22, 24) (k1, l1, k2, l2, k3, l3) - (11, 12, 14) |

Maximum rated voltage of the system being monitored (conductor to be monitored directly connected)

| | |
|---------------------------------------|----------|
| With protective separation | AC 230 V |
| Without protective separation | AC 400 V |
| Voltage test according to IEC 61010-1 | 2.21 kV |

Supply voltage

CMD420-D-1, CMD421-D-1:

| | |
|------------------------------|------------------------------|
| Rated supply voltage U_5 | AC 16...72 V / DC 9,6...94 V |
| Rated supply frequency U_5 | DC, 15...460 Hz |

CMD420-D-2, CMD421-D-2:

| | |
|------------------------------|------------------|
| Rated supply voltage U_5 | AC/DC 70...300 V |
| Rated supply frequency U_5 | DC, 15...460 Hz |
| Power consumption | ≤ 4 VA |

Measuring circuit, CMD420

| | |
|--------------------------------|---------------|
| Effective measuring range, n=1 | AC 0...1 A |
| Overload capacity, continuous | 2 A |
| Overload capacity < 5 s | 5 A |
| Burden | 50 m Ω |

| | |
|-----------------------|-------------|
| Rated frequency f_n | 42...460 Hz |
|-----------------------|-------------|

Response values, CMD420

| | |
|--|--|
| Undercurrent $I_o < I$ (Alarm 2) n = 1 | AC 0.1...1 A (0.3 A)* |
| Undercurrent $I_o < I$ (Alarm 1) n = 1 | 100 %...200 % (150 %)* Maximum of 1 A |
| Overcurrent $I_i > I$ (Alarm 2) n = 1 | AC 0.1...1 A (0,3 A)* (Hi)* |
| Overcurrent $I_i > I$ (Alarm 1) n = 1 | 50 %...100 % (50 %)* (Hi)* |
| Window $I_n > I$ (Alarm 2) n = 1 | AC 0.1...1 A (0,3 A)* |
| Window $I_n < I$ (Alarm 1) n = 1 | 50 %...100 % (50 %)* |
| External current transformer ratio | x/1 A (1 A secondary) |
| Transformer ratio setting factor n | 1...2000 (1)* |
| Relative percentage error at 42...460 Hz | ± 5 %, ± 2 digit |
| Hysteresis | 3...40 % (15 %)* |

Measuring circuit, CMD421

| | |
|--------------------------------|--|
| Effective measuring range, n=1 | AC 0...5 A |
| Overload capacity, continuous | 7.5 A |
| Overload capacity < 5 s | Screw terminal versions: 20 A Cage clamp versions: 12 A |
| Burden | 3 m Ω |
| Rated frequency f_n | 42...460 Hz |

Response values, CMD421

| | |
|--|--|
| Undercurrent $I_o < I$ (Alarm 2) n = 1 | AC 0.5...5 A (1,5 A)* |
| Undercurrent $I_o < I$ (Alarm 1) n = 1 | 100 %...200 % (150 %)* Maximum of 5 A |

Technical data (continued from previous page)

| | | | |
|--|-----------------------------|---------------------------|--|
| Overcurrent $I_n > I$ (Alarm 2) $n = 1$ | AC 0.5...5 A (1,5 A)* (Hi)* | Flexible without ferrules | 0.2...2.5 mm ² (AWG 24...14) |
| Overcurrent $I_n > I$ (Alarm 1) $n = 1$ | 50 %...100 % (50 %)* (Hi)* | Flexible with ferrules | 0.2...1.5 mm ² (AWG 24...16) |
| Window $I_n > I$ (Alarm 2) $n = 1$ | AC 0.5...5 A (1,5 A)* | Stripping length | 10 mm |
| Window $I_n < I$ (Alarm 1) $n = 1$ | 50 %...100 % (50 %)* | Opening force | 50 N |
| External current transformer ratio | x/5 A (5 A secondary) | Test opening, diameter | 2.1 mm |
| Transformer ratio setting factor n | 1...2000 (1)* | | |
| Relative percentage error at 42...460 Hz | ± 5 %, ± 2 digit | | |
| Hysteresis | 3...40 % (15 %)* | | |

Specified times

| | |
|--|-------------------------------|
| Start-up delay t | 0...300 s (0.5 s)* |
| Response delay t_{on1} | 0...300 s (1 s)* |
| Response delay t_{on2} | 0...300 s (0 s)* |
| Delay on release t_{off} | 0...300 s (0.1 s)* |
| Time delay increment: t, $t_{on1/2}$, t_{off} (0...10 s range) | 0.1 s |
| Time delay increment: t, $t_{on1/2}$, t_{off} (10...99 s range) | 1 s |
| Time delay increment: t, $t_{on1/2}$, t_{off} (100...300 s range) | 10 s |
| Operating time t_{ae} | ≤ 130 ms |
| Response time t_{an} | $t_{an} = t_{ae} + t_{on1/2}$ |
| Operating release time t_{re} | ≤ 130 ms |
| Release time t_{aus} | $t_{aus} = t_{re} + t_{off}$ |
| Recovery time t_b | ≤ 300 ms |

Displays, memory

| | |
|-------------------------------------|--|
| Display type | LCD display ,multifunctional |
| Display range measured value (x n) | CMD420: AC 0...1 A x n CMD421: AC 0...5 A x n |
| Display error at 42...460 Hz | ± 5 % ± 2 digit |
| Measured value (HiS) for last alarm | Last recorded alarm |
| Password | off / 0...999 (off)* |
| Latching capability | on / off / con (on)* |

Switching elements

| | |
|---|---|
| Number of changeover contacts | 2 SPDT relays |
| Operating principle | Normally energized or normally de-energized |
| Electrical service life | 10.000 switching operations |
| Contact data acc. to IEC 60947-5-1 | |
| Utilization category | AC-13 AC-14 DC-12 DC-12 DC-12 |
| Rated operational voltage | 230 V 230 V 24 V 110 V 220 V |
| Rated operational current | 5 A 3 A 1 A 0.2 A 0.1 A |
| Minimum contact load / gold-plated relay contacts | 1 mA at AC/DC ≥ 10 V |

Environment / EMC

| | |
|---|--|
| EMC | IEC 61326-1 |
| Operating temperature | -13 °F...+131 °F (-25 °C...+55 °C) |
| Climatic class acc. to IEC 60721 | |
| Stationary use (IEC 60721-3-3) | 3K5 (except condensation and formation of ice) |
| Transport (IEC 60721-3-2) | 2K3 (except condensation and formation of ice) |
| Long-time storage (IEC 60721-3-1) | 1K4 (except condensation and formation of ice) |
| Classification of mechanical conditions IEC 60721 | |
| Stationary use (IEC 60721-3-3) | 3M4 |
| Transport (IEC 60721-3-2) | 2M2 |
| Long-time storage (IEC 60721-3-1) | 1M3 |

Connection

| | |
|------------------------|--|
| Connection | push-wire terminals |
| Connection properties: | |
| rigid | 0.2...2.5 mm ² (AWG 24...14) |

Other

| | |
|---|--|
| Operating mode | continuous operation |
| Position of normal use | any |
| Degree of protection, internal components (IEC 60529) | IP30 (NEMA 1) |
| Degree of protection, terminals (IEC 60529) | IP20 (NEMA 1) |
| Enclosure material | polycarbonate |
| Flammability class | UL94V-0 |
| DIN rail mounting acc. to | IEC 60715 |
| Screw mounting | 2 x M4 with mounting clip |
| Product standard | IEC 61010-1 and according to IEC 60255-6 |
| Firmware version, CMD420 | D287 V1.1x |
| Firmware version, CMD421 | D294 V1.1x |
| Weight | ≤ 160 g |

() * factory setting



USA • Coatesville, PA
Toll-Free: 800-356-4266 • Main: 610-383-9200
Fax: 610-383-7100 • E-mail: info@bender.org



Canada • Mississauga, ON
Toll-Free: 800-243-2438 • Main: 905-602-9990
Fax: 905-602-9960 • E-mail: info@bender-ca.com

bender.org • bender.org/mobile