



MRCDB300-series

**AC/DC sensitive residual current monitoring module
for MRCD applications**





Bender GmbH & Co. KG

Postfach 1161 • 35301 Grünberg • Germany
Londorfer Str. 65 • 35305 Grünberg • Germany
Tel.: +49 6401 807-0 • Fax: +49 6401 807-259
E-Mail: info@bender.de • www.bender.de

© Bender GmbH & Co. KG

Alle Rechte vorbehalten.
Nachdruck nur mit Genehmigung des Herausgebers.
Änderungen vorbehalten!

Fotos: Bender Archiv

Inhaltsverzeichnis

1. General instructions	7
1.1 How to use this manual	7
1.2 Technical support: service and support	7
1.3 Training courses	8
1.4 Delivery conditions	9
1.5 Inspection, transport and storage	9
1.6 Warranty and liability	9
1.7 Disposal	10
2. Safety instructions	11
2.1 General safety instructions	11
2.2 Work activities on electrical installations	11
2.3 Intended use	11
3. Device description	13
3.1 Area of application	13
3.2 Device features	13
3.3 Variants	14
3.4 Functional description	16
4. Installation and connection	17
4.1 Composition of an MRCD module	17
4.2 Installing the device	18
4.2.1 Dimension diagrams	18
4.2.2 Mountings	19
4.3 Assembly	19
4.4 Connecting the device	20
4.4.1 Device view MRCD30...	20
4.5 Wiring diagrams	21
4.5.1 N/C principle without contact feedback	21
4.5.2 N/C principle with contact feedback	22
4.5.3 N/O principle without contact feedback	23
4.5.4 N/O principle with contact feedback	24

4.6	Connection RS-485 interface (Modbus RTU)	25
4.7	Installation instructions for measuring current transformers	26
4.7.1	Protective conductors and live conductors	26
4.7.2	Bending cables	26
4.7.3	Routing cables centrally	26
5.	Commissioning	27
5.1	Setting addresses	27
5.2	Offset calibration	29
5.3	Completing and checking installation	30
6.	Test, reset, function test	31
6.1	Periodic self test	31
6.2	Manual self test	31
6.2.1	Integrated "T" button	31
6.2.2	External test/reset button	31
6.3	Function test	32
7.	Modbus register	33
7.1	Overview	33
7.1.1	Read and write accesses	33
7.1.2	Formats used	33
7.1.3	Register areas	34
7.1.4	Representation of values	34
7.1.5	Alarm assignments	35
7.1.6	Descriptions	35
7.2	Device information	35
7.3	Detailed measured values	37
7.4	General measured values	38
7.4.1	Device error and status information.....	39
7.5	History	40
7.6	Device parameters and factory settings	41
7.7	Control commands	46
7.8	Additional function codes:	48
7.8.1	Diagnostic (function code 0x08)	48
7.8.2	Get Com Event Counter (function code 0x0B)	48
7.8.3	Report Server ID (function code 0x11)	49
7.8.4	Device Identification (function code 0x2B)	49

8. System states: LED and output relays 51

9. Error codes 53

10. Frequency responses 55

 10.1 Low passes LP 55

 10.2 Type B+ 55

 10.3 Type B 56

 10.4 Fire protection 100 kHz 56

11. Technical data 57

 11.1 Tabular data 57

 11.2 Standards and certifications 61

 11.3 Ordering details 61

 11.3.1 Electronic modules 61

 11.3.2 Measuring current transformers 62

 11.3.3 Accessories 62

 11.3.4 Suitable system components 62

INDEX 63

1. General instructions

1.1 How to use this manual



This manual is intended for **qualified personnel** working in electrical engineering and electronics!

Always keep this manual within easy reach for future reference. We have used the following symbols to identify important instructions and information:



This signal word indicates that there is a **high risk of danger** that will result in **death** or **serious injury** if not avoided.



This signal word indicates a **medium risk** of danger that can lead to **death** or **serious injury**, if not avoided.



This signal word indicates a **low-level risk** that can result in **minor** or **moderate injury or damage to property** if not avoided.



This symbol denotes information intended to assist the user in making **optimum use** of the product.

1.2 Technical support: service and support

For commissioning and troubleshooting Bender offers:

First level support

Technical support by phone or e-mail for all Bender products

- Questions about specific customer applications
- Commissioning
- Troubleshooting

Telephone: +49 6401 807-760*

Fax: +49 6401 807:-259 Germany: 0700BenderHelp (telephone and fax)

E-mail: support@bender-service.de

Repair service

Repair, calibration, update and replacement service for all Bender products

- Repair, calibration, testing and analysis
- Hardware and software update
- Delivery of replacement devices for faulty or incorrectly delivered devices
- Extended warranty with in-house repair service or replacement device at no extra cost

Telephone: +49 6401 807-780** (technical issues)/

+49 6401 807-784**, -785** (commercial issues)

Fax: +49 6401 807-789

E-mail: repair@bender-service.de

Please send the devices for repair to the following address:

Bender GmbH, Repair-Service, Londorfer Straße 65, 35305 Grünberg

Field service

On-site service for all Bender products

- Commissioning, parameter setting, maintenance, troubleshooting
- Analysis of the electrical installation in the building (power quality test, EMC test, thermography)
- Practical training courses for customers

Telephone: +49 6401 807-752**, -762 ** (technical issues)/

+49 6401 807-753** (commercial issues)

Fax: +49 6401 807-759

E-mail: fieldservice@bender-service.de

Internet: www.bender.de

*Available from 7.00 a.m. to 8.00 p.m. on 365 days of the year (CET/UTC +1)

**Mo-Thu 7.00 a.m. - 4.00 p.m., Fr 7.00 a.m. - 1.00 p.m

1.3 Training courses

Bender is happy to provide training regarding the use of test equipment.

The dates of training courses and workshops can be found on the Internet at www.bender.de -> Know-how -> Seminars.

1.4 Delivery conditions

The conditions of sale and delivery set out by Bender apply.

For software products, the "Softwareklausel zur Überlassung von Standard- Software als Teil von Lieferungen, Ergänzung und Änderung der Allgemeinen Lieferbedingungen für Erzeugnisse und Leistungen der Elektroindustrie" (software clause in respect of the licensing of standard software as part of deliveries, modifications and changes to general delivery conditions for products and services in the electrical industry) set out by the ZVEI (Zentralverband Elektrotechnik- und Elektronikindustrie e.V., (German Electrical and Electronic Manufacturers' Association) also applies.

Conditions of sale and delivery can be obtained from Bender in printed or electronic format.

1.5 Inspection, transport and storage

Inspect the dispatch and equipment packaging for damage, and compare the contents of the package with the delivery documents. In the event of damage in transit, please contact Bender immediately.

The devices must only be stored in areas where it is protected from dust, humidity and spray or dripping water, and in which the specified storage temperatures can be assured.

1.6 Warranty and liability

Warranty and liability claims in the event of injury to persons or damage to property are excluded if they can be attributed to one or more of the following causes:

- Improper use of the device.
- Incorrect mounting, commissioning, operation and maintenance of the device.
- Failure to observe the instructions in this operating manual regarding transport, commissioning, operation and maintenance of the device.
- Unauthorised changes to the device made by parties other than the manufacturer.
- Non-observance of technical data.
- Repairs carried out incorrectly and the use of replacement parts or accessories not approved by the manufacturer.
- Catastrophes caused by external influences and force majeure.
- Mounting and installation with device combinations not recommended by the manufacturer.

This operating manual, especially the safety instructions, must be observed by all personnel working on the device. Furthermore, the rules and regulations that apply for accident prevention at the place of use must be observed.

1.7 Disposal

Abide by the national regulations and laws governing the disposal of this device. Ask your supplier if you are not sure how to dispose of the old equipment.

The directive on waste electrical and electronic equipment (WEEE directive) and the directive on the restriction of certain hazardous substances in electrical and electronic equipment (RoHS directive) apply in the European Community. In Germany, these policies are implemented through the "Electrical and Electronic Equipment Act" (ElektroG). According to this, the following applies:

- Electric and electronic equipment are not to be included in household waste.
- Batteries and accumulators are not to be included in household waste but must be disposed of in accordance with the regulations.
- Old electrical and electronic equipment from users other than private households which was introduced to the market after 13 August 2005 must be taken back by the manufacturer and disposed of properly.

For more information on the disposal of Bender devices, refer to our website at www.bender.de -> Service & support.

For more information on the disposal of Bender devices, refer to our website at www.bender.de -> Service & support.

2. Safety instructions

2.1 General safety instructions

Part of the device documentation in addition to this manual is the enclosed " Safety instructions for Bender products".

2.2 Work activities on electrical installations



Only **qualified personnel working in electrical engineering and electronics** are permitted to carry out the work necessary to install, commission and run a device or system.



DANGER

Risk of electrocution due to electric shock!

Touching live parts of the system carries the risk of:

- An electric shock
- Damage to the electrical installation
- Destruction of the device

Before installing and connecting the device, make sure that the **installation** has been **de-energised**. Observe the rules for working on electrical installations.

Refer to the rated and supply voltage values as specified in the technical data!

If the device is used outside the Federal Republic of Germany, the applicable local standards and regulations must be complied with. The European standard EN 50110 can be used as a guide.

2.3 Intended use

The AC/DC sensitive residual current monitors of type MRCDB30... are used in combination with a CTBC... measuring current transformer and a circuit breaker according to IEC 60947-2 as additional protection in industrial power supplies. According to IEC 60364-5-53, the use in earthed power supplies (TN and TT systems) up to 800 V is possible. These devices are suitable for monitoring AC and DC fault currents (type B).

Any other use than that described in this document is regarded as improper.

3. Device description

3.1 Area of application

The AC/DC sensitive device series MRCDB30... is used in combination with a CTBC... as additional protection (protection against indirect contact) in earthed systems (TN and TT systems) in which AC or DC fault currents may occur.

Part of these systems are particularly loads containing six-pulse rectifiers or one-way rectifiers with smoothing, such as converters, battery chargers, construction site equipment with frequency-controlled drives. When the response value $I_{\Delta n1}$ (prewarning) is reached, the output relay K1 switches. When the response value $I_{\Delta n2}$ (alarm) is reached, the output relay K2 also switches.

By using an MRCDB30... module and a switching element with isolating properties, the device combination fulfils the requirements of IEC 60947-2 Annex M for an MRCD protective device.

The application is specifically intended for protection goals such as protection of persons, fire protection and plant protection. The switching element must not exceed a switch-off time of 20 ms.

The CTBC...P series measuring current transformers feature an integrated magnetic shield and are suitable for applications with high load currents or inrush currents.

3.2 Device features

- Structure of a protective device in accordance with IEC 60947-2 Annex M in combination with a circuit breaker providing isolating properties
- Monitoring of the connected circuit breaker by means of contact feedback
- RS-485 interface with Modbus RTU (reading out measured values/setting parameters)
- Integrated switching outputs with two changeover contacts K1 and K2 (galvanically isolated)
- Fulfils the protection goals protection of persons, fire protection and plant protection (depending on the variant)
- Frequency range (depending on the variant) DC...100 kHz
- Combined test and reset button
- Multicolour LED indicating operation, exceeded response value, disturbances and status messages

- AC/DC sensitive type B measured value acquisition acc. to IEC 60755 (depending on the variant)
- AC/DC sensitive type B+ measured value acquisition acc. to VDE 0664-400 (depending on variant)
- Exchangeable electronic enclosure without mechanical separation of the primary conductors
- Extension/retrofitting or modification of functionalities in case of changed monitoring requirements
- Insensitive to load currents due to full magnetic shield (CTBC...**P** only)
- Connection monitoring of the measuring current transformer with cyclical test current
- Use of all MRCDB30... for all CTBC... measuring current transformer sizes
- Supply voltage DC 24 V

3.3 Variants

Electronic modules

- **MRCDB301**
Type B modular residual current protective device acc. to IEC 60755 for the **protection of persons** in case of indirect contact, response value 30 mA;
- **MRCDB302**
Type B+ modular residual current protective device acc. to VDE 0664-100 for **fire protection**, response value 300 mA;
- **MRCDB303**
Modular residual current protective device for **plant protection** (N/C operation), freely configurable
- **MRCDB304 (only on request)**
Modular residual current protective device for **plant protection** (N/O operation), freely configurable

Measuring current transformers

- **CTBC20** Measuring current transformer, internal diameter 20 mm
- **CTBC20P** Measuring current transformer shielded, internal diameter 20 mm
- **CTBC35** Measuring current transformer, internal diameter 35 mm
- **CTBC35P** Measuring current transformer shielded, internal diameter 35 mm
- **CTBC60** Measuring current transformer, internal diameter 60 mm
- **CTBC60P** Measuring current transformer shielded, internal diameter 60 mm
- **CTBC120** Measuring current transformer, internal diameter 120 mm
- **CTBC120P** Measuring current transformer shielded, internal diameter 120 mm
- **CTBC210** Measuring current transformer, internal diameter 210 mm
- **CTBC210P** Measuring current transformer shielded, internal diameter 210 mm

3.4 Functional description

Residual current $I_{\Delta n}$

The residual current monitoring module measures both AC and DC currents. Tripping takes place based on the determined r.m.s. value. When the response value set for $I_{\Delta n2}$ (alarm) is exceeded by a residual current, the output relay K2 switches an undervoltage release (recommended) or a shunt release (N/O operation) within the required tripping time and the LED lights up red.

If the fault memory behaviour of relay K1 or K2 is activated, the device must be reset by pressing the "T" button.

The MRCD module automatically checks the measuring current transformer and the function of the residual current measurement cyclically.

Offset calibration

When the device has been *installed*, an offset calibration should first be carried out (see page 29). After successful offset calibration, the multicolour LED lights up green and the device is ready for operation.

Test

Press the "T" button or the external test button for 5...10 s to start the manual self test of the device.

Reset

Press the "T" button or the external test button for 1.5...5 s to reset the device.

Contact feedback

The contact feedback ensures that the circuit breaker is in the desired switching state.

RS-485 interface

The RS-485 interface enables both reading out the measured values and setting the parameters of the device via Modbus RTU. Furthermore, a test or a reset can be triggered via the bus.

Switch-off control (MRCDB3... only)

After an alarm, the measured I_{Δ} (r.m.s.) must be lower than $0.5 \times I_{\Delta n}$ of the smallest alarm limit value active via alarm assignment, so that K2 switches on again. If the residual current is permanently higher, this is a sign of a welded contactor or incorrect wiring. The device displays an error (error code: 0.56).

4. Installation and connection



Only **qualified personnel working in electrical engineering and electronics** are permitted to carry out the work necessary to install, commission and run a device or system.



DANGER

Risk of electrocution due to electric shock!

Touching live parts of the system carries the risk of:

- An electric shock
- Damage to the electrical installation
- Destruction of the device

Before installing and connecting the device, make sure that the installation has been de-energised. Observe the rules for working on electrical installations.

Refer to the rated and supply voltage values as specified in the technical data!

4.1 Composition of an MRCD module

Any combination of electronic modules (MRCDB30...) and measuring current transformers (CTBC...) is possible to enable individual adaptation to every installation situation.

4.2 Installing the device

4.2.1 Dimension diagrams

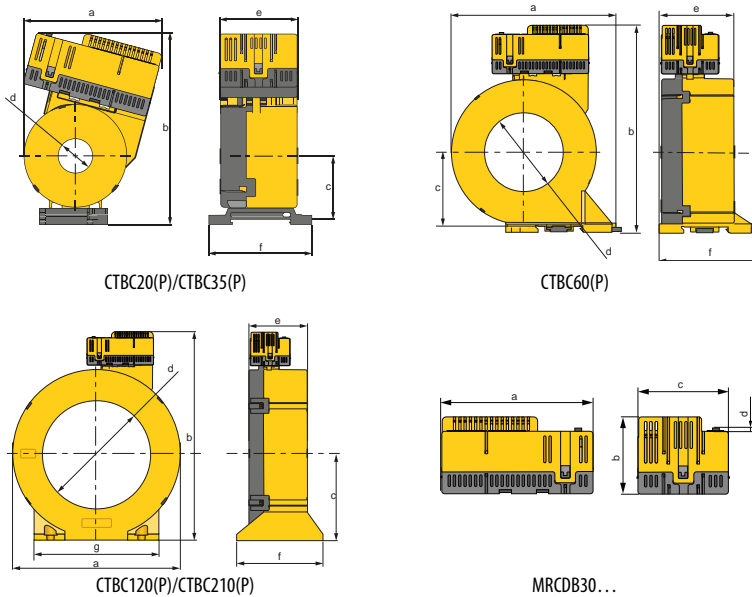
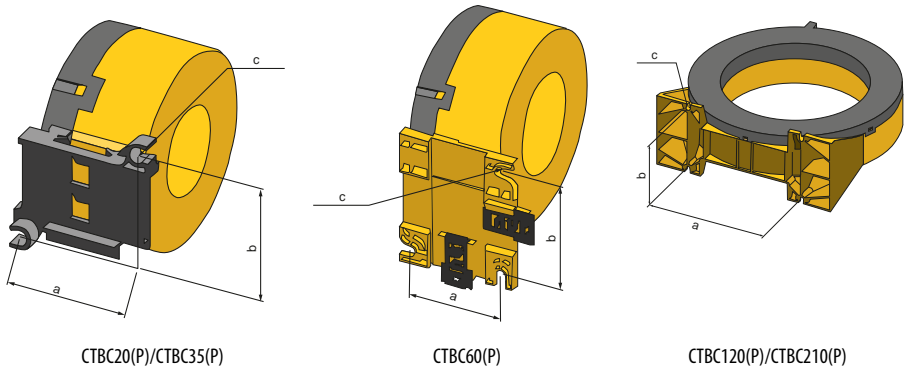

Fig. 4.1: Dimension diagrams CTBC... and MRADB30...

Type	a	b	c	d	e	f	g
MRCDB3...-CTBC20(P)	81	112	37	∅ 20	46	60	
MRCDB3...-CTBC35(P)	97	130	47	∅ 35	46	61	
MRCDB3...-CTBC60(P)	126	158	57	∅ 60	56	78	
MRCDB3...-CTBC120(P)	188	232	96	∅ 120	65	96	139
MRCDB3...-CTBC210(P)	302	346	153	∅ 210	67	113	277
MRCDB30x	74	37	44	2	4.6		

All dimensions in mm, tolerance ± 0.5 mm

4.2.2 Mountings



Type	a	b	c
CTBC20(P)	31.4	49	2 x Ø 5.5
CTBC35(P)	49.8	49	2 x Ø 5.5
CTBC60(P)	56	66	2 x Ø 6.5
CTBC120	103	81	4 x Ø 6.5
CTBC210	180	98	4 x Ø 5.5

all dimensions in mm, tolerance ± 0.5 mm

4.3 Assembly

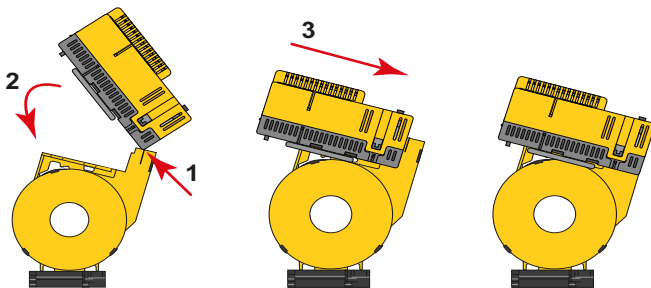

Fig. 4.2: Assembly electronic module

Steps

1. Place the electronic module on the mark on the measuring current transformer.
2. Fold the electronic module down onto the measuring current transformer.
3. Slide the electronic module onto the plug contacts of the measuring current transformer.

4.4 Connecting the device



DANGER

Risk of electrocution due to electric shock!

Touching live parts of the system carries the risk of:

- An electric shock
- Damage to the electrical installation
- Destruction of the device

Before installing and connecting the device, make sure that the installation has been de-energised. Observe the rules for working on electrical installations.

Refer to the rated and supply voltage values as specified in the technical data!

4.4.1 Device view MRCDB30...

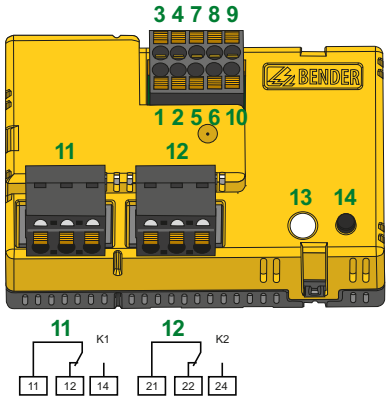
	No.	Terminal	Meaning
	1	24 V	Supply voltage U_s
	2	GND	
	3	D1	Contact feedback
	4	DG	
	5	T/R	Connection external test/reset
	6	GND	
	7	A	RS-485 interface
	8	B	
	9	X1	Terminals for cable bridge for connection of the integrated terminating resistor of the RS-485 interface
	10	X2	
	11	11, 12, 14	Relay K1 (prewarning)
	12	21, 22, 24	Relay K2 (alarm)
	13	–	Combined LED refer to "System states" section
	14	–	Test and reset button "T"

Tab. 4.1: Device view MRCDB30...

4.5 Wiring diagrams

The following applies to all wiring diagrams:

- The use of a type 2 surge protection device (SPD) is mandatory due to possible impulse voltages and in order to comply with normative requirements.
- The surge protection device must be connected upstream of the power supply unit on the supply side.
- Features of the surge protection device:
 - Nominal discharge current I_n (8/20 μ s): 20 kA
 - Response time: 25 ns
 - Two-stage: 1 varistor + 1 spark gab

Alternatively, the power supply unit can be connected to a CAT II supply without a surge protection device.

4.5.1 N/C principle without contact feedback

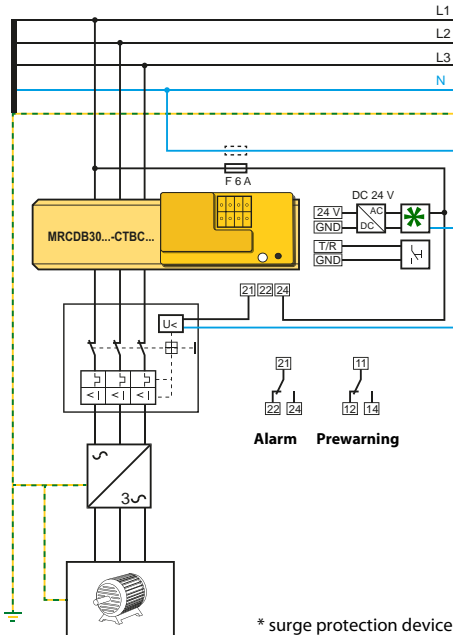

Fig. 4.3: Wiring diagram MRCDB30... (N/C principle, without contact feedback)

4.5.2 N/C principle with contact feedback

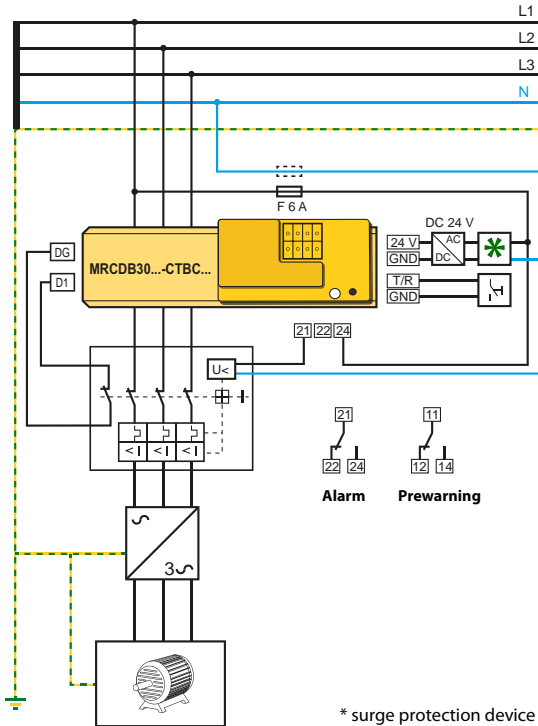

Fig. 4.4: Wiring diagram MRCDB30... (N/C principle with contact feedback)

The contact feedback ensures that the trip circuit is in the desired switching state. If due to events such as

- burnt relay contacts (K2) on the MRCDB30...
- mechanical jam of the circuit breaker
- incorrect wiring

no separation at the circuit breaker takes place, the feedback signal contacts (D1/DG) cannot signal a change of state.

A failure of the trip circuit, which would otherwise go undiscovered, is detected immediately. This information can be forwarded via the RS-485 interface or relay K1 to a control centre.

4.5.3 N/O principle without contact feedback

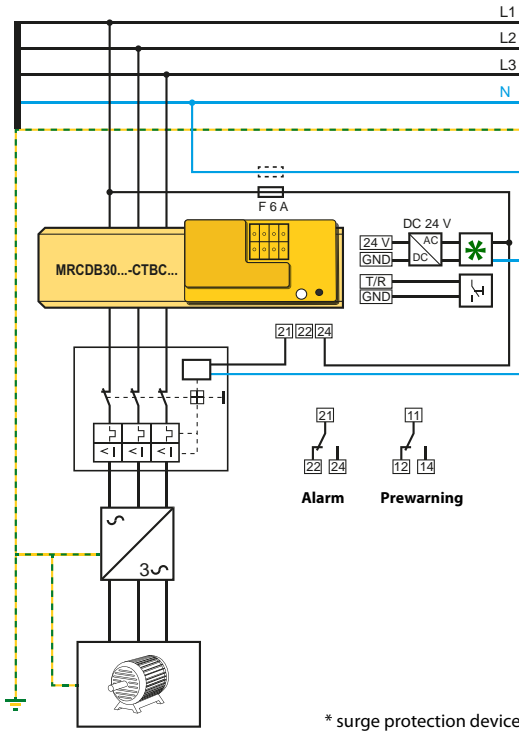

Fig. 4.5: Wiring diagram MRCDB30...(N/O principle without contact feedback)

4.5.4 N/O principle with contact feedback

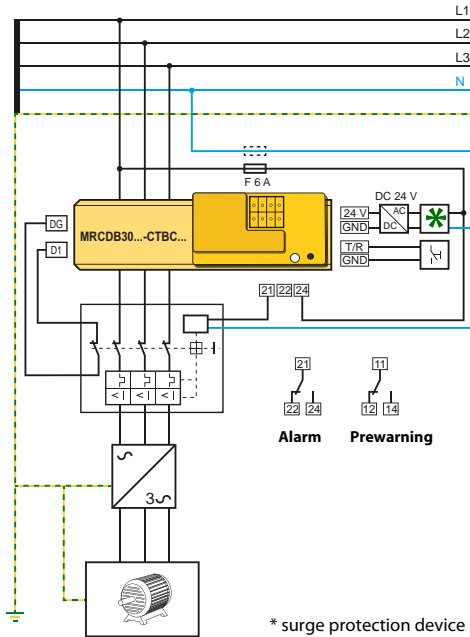

Fig. 4.6: Wiring diagram MRADB30... (N/O principle with contact feedback)



We recommend operating the alarm relay K1 according to the N/C principle. This allows detecting and reporting the failure of the supply voltage and the internal power supply unit.

For economical installation reasons, **alarm relay K2 can** be operated according to the **N/O principle**. Due to this operating principle, the following aspects should be observed **to minimise the risks**:

1. The risk assessment intervals should be **shorter**.
2. Due to the **contact feedback** via the measuring inputs D1 and DG, the following fault types are detected and signalled as alarms via the alarm relay K1:
 - Interruption of the connecting line from the alarm relay K2 to the shunt release (N/O operation)
 - Mechanically defective circuit breaker
 - Defective output relay K2 for controlling the shunt release (N/O operation)

4.6 Connection RS-485 interface (Modbus RTU)

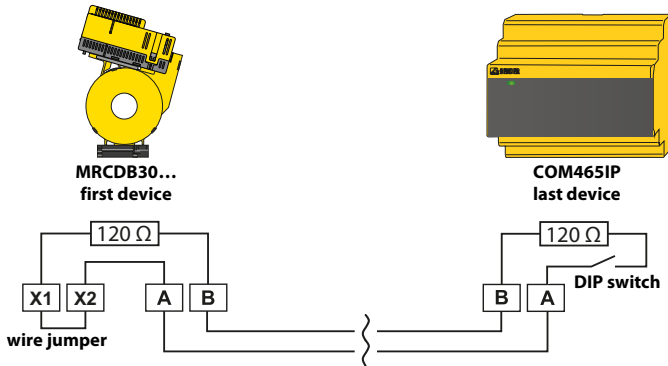

Fig. 4.7: Connection RS-485 interface

The internal $120\ \Omega$ terminating resistor can be connected by using the **wire jumper**.
The internal $120\ \Omega$ terminating resistor can be connected by means of the **DIP switch**.

4.7 Installation instructions for measuring current transformers



Do not route any shielded cables through the measuring current transformer!



CAUTION

Device damage due to high induction currents!

High currents can be induced into the conductor loop due to the AC/DC sensitive measurement technology used. Do not route protective conductors and low-resistance conductor loops through the measuring current transformer!

Device damage due to interference pulses!

The connecting cable (supply, analogue interface ...) must not be routed directly past the current transformer core.

Risk of injury due to accessible live conductors!

The measuring current transformer must be connected to the corresponding evaluator before the first use and before commissioning of the monitored system.

4.7.1 Protective conductors and live conductors

Make sure that all **current-carrying cables** are routed through the measuring current transformer.

Never route an existing **protective conductor** through the measuring current transformer.

The **cable diameter** may not exceed half the current transformer diameter.

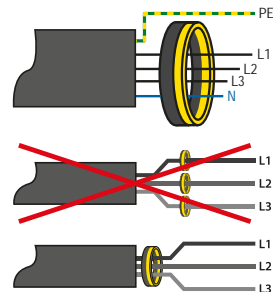

4.7.2 Bending cables

The cables may only be bent at a certain distance from the measuring current transformer.

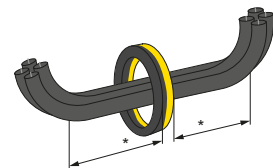

4.7.3 Routing cables centrally

The cables must be aligned with the centre of the measuring current transformer.

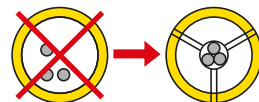

5. Commissioning

5.1 Setting addresses

Every MRCDB3... has a factory-set Modbus address. The address is 1XX, where XX = the last two digits of the serial number.



Example:
Serial number = 123456**78** --> Modbus address = 178

If the preset address is to be changed, this can be done

- via a COMTRAXX® gateway,
- via Modbus,
- directly on the device.

The address can be changed on the device before installation and offset calibration.



The electronic module must not be connected to the measuring current transformer during address setting (for disassembly refer to chapter 4.4).



Each address in the bus system may only be assigned once.

The LED has various flashing patterns, which indicate the state of the module:

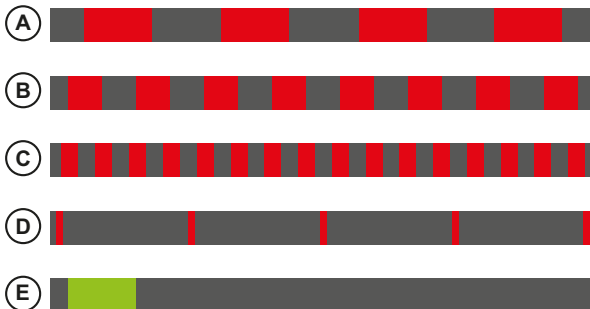

Address modification procedure

Phase	Action		LED
1	Supply the electronic module with power		Flashes red (A, error: no measuring current transformer)
2	Press and hold "T" until the LED flashes red very quickly; release afterwards		Flashes red (A, error)
			Flashes red quickly (B, mode change)
			Flashes red quickly (C, ready for address setting mode)
3	Set address (address setting range: 1...247)		Flashes red very quickly (D, address setting mode)
3a	Units place	Press "T" repeatedly until reaching the desired digit of the units place	Each keystroke is confirmed with green (E)
		Acknowledge the entry: Press and hold "T" until the LED flashes red; release afterwards	Lights green shortly (E) LED flashes red (C)
3b	Tens place	Press "T" repeatedly until reaching the desired digit of the tens place	Each keystroke is confirmed with green (E)
		Acknowledge the entry: Press and hold "T" until the LED flashes red; release afterwards	Lights green shortly (E) LED flashes red (C)
3c	Hundreds place	Press "T" repeatedly until reaching the desired digit of the hundreds place	Each keystroke is confirmed with green (E)
		Acknowledge the entry: Press and hold "T" until the LED flashes red; release afterwards	Lights green shortly (E) LED flashes red (C)
4	Check address setting: LED indicates the address by flashing ¹⁾		
		Digit units place	Flashes green for each number (E)
		Pause	off
		Digit tens place	Flashes green for each number (E)
		Pause	off
		Digit hundreds place	Flashes green for each number (E)
	Pause	off	
5	Address set		Flashes red (A, error: no measuring current transformer)

Tab. 5.1: Procedure address setting on electronic module

¹⁾ Example for "Check address setting". Address "124" is to be set. Successful configuration results in the following flashing pattern:



5.2 Offset calibration

The residual current monitoring module must be calibrated to the system to be monitored so that the selected protective function can be fulfilled. Each electronic module MRCDB30... must be individually calibrated to the CTBC... **built-in measuring current transformer**. Calibration can be carried out by means of the "T" button or via the Modbus interface.

A calibration must always be performed in case of:

- New installation
- A replacement of a CTBC... measuring current transformer
- A replacement of an MRCDB30... electronic module
- A modification of the response value

In case of response values > 300 mA, no offset calibration is required.

If the device is not calibrated, the LED lights red permanently, commissioning is not possible. Note that during the offset calibration the system is switched off and no current flows through the measuring current transformer.

If a current flows through the measuring current transformer despite the system being switched off, this indicates a device error. Replace the measuring current transformer immediately.



The alarm relays switch to safe state during offset calibration (system is switched off).

Procedure of the first offset calibration

Phase	Action	LED
1	Install the measuring current transformer in the system	off
2	Plug the electronic module and the measuring current transformer together (see Chapter 4.5)	off
3	Disconnect the electronic module from the supply voltage	off
4a	Press and hold the "T" button	off
4b	Press and hold the "T" button, supply the electronic module with supply voltage U_{ζ}	lights red permanently (not ready for operation)
		flashes red slowly (A) (ready for calibration)
		flashes red quickly (B) (calibration mode)
5	Start calibration: release "T"	
6	Calibration in progress	flashes red quickly (B)
7	Calibration successful, values are accepted, relay switches	lights green permanently
8	Calibration finished, normal operating status	lights green permanently

5.3 Completing and checking installation

The installation must be completed with a function test.

This is done by means of a manual self test (for details refer to Chapter 6.2).

6. Test, reset, function test

6.1 Periodic self test

The MRCDB... electronic module carries out a self diagnosis at regular intervals and thus ensures the device function. The electronic module feeds a test current into the test winding of the measuring current transformer.



*During a periodic self test, the electronic module **does not switch off the circuit breaker**. However, if a system fault is detected, the output relay and the external circuit breaker are used to switch off.*

6.2 Manual self test

6.2.1 Integrated "T" button

ResetPress the button for 1.5...5 s

TestPress the button for 5...10 s

The integrated "T" button allows local performance of a function test at any time. The button is useful during commissioning, repair measures and recurring tests by the plant operator.

The "T" button can be used to delete a fault message of the tripped MRCD (reset).

The integrated "T" button is electrically decoupled from the external test/reset connection. This ensures that, of all MRCDs connected via the T/R connection, only the local MRCD acts.

6.2.2 External test/reset button

ResetPress the button for 1.5...5 s

TestPress the button for 5...10 s

The external test/reset button can be used to perform function tests without having to open a control cabinet or reach an installation location that is difficult to access. Another option is to carry out a collective test, i.e. a function test of several installed MRCDs at the same time.

6.3 Function test

The system operator is obliged to have the MRCD protective devices checked at regular intervals by an electrically skilled person to ensure that they are functioning properly. This requirement is deemed to be satisfied for normal and environmental conditions if the test intervals mentioned in DGUV V3 (German Social Accident Insurance Regulation 3) are adhered to. The test intervals are to be interpreted in accordance with the risk assessment.

The recurrent tests must include at least the following:

- Testing the environmental conditions for pollution, mechanical damage or insulation damage.
- To trip the circuit breaker, the integrated or the external test button is to be pressed.

7. Modbus register

This chapter provides a complete description of the Modbus register for the MRCDB300/RCMB300 series to allow access to information.

The following Modbus function codes are supported:

- Holding register for reading out values
(Read Holding Register; function code 0x03)
- Register for device programming
(Write Multiple Registers; function code 0x10)
- Register for diagnostic functions
(Diagnostic; function code 0x08)
- Register for event counter
(Get Com Event Counter; function code 0x0B)
- Register for server ID
(Report Server ID; function code 0x11)
- Register for device identification
(Read Device Identification; function code 0x2B)

For a complete Modbus protocol specification, visit <http://www.modbus.org>.

7.1 Overview

7.1.1 Read and write accesses

RO	READ ONLY (read access only)
RW	READ / WRITE (read and write access)
WO	WRITE ONLY (write access only)

7.1.2 Formats used

Float32	IEEE754 32-bit (single precision floating point number)
INT16	Signed 16-bit integer
INT32	Signed 32-bit integer
UINT16	Unsigned 16-bit integer
UINT32	Unsigned 32-bit integer
String-UTF8	ASCII character string

7.1.3 Register areas

Area	Start address	End address
Info	0	3999
Detailed measured values	4000	7999
Simple measured values	8000	11999
History	12000	15999
Parameters	16000	19999
Control commands	20000	23999
Reserved	24000	27999
Reserved	60000	60099

7.1.4 Representation of values

	Value	Description
Test status	0	No test
	1	Internal test
	2	External test
Alarm status	0	No alarm
	1	Prewarning
	2	Error
	3	Reserved
	4	Warning
	5	Alarm
Range	0	=
	1	<
	2	>
	3	Invalid
Unit	0	Invalid
	1	None
	2	Ohm
	3	Ampere
	4	Volt
	5	Percent

	Value	Description
Unit	6	Hertz
	7	Baud
	8	Farad
	9	Henry
	10	Degree Celsius
	11	Degree Fahrenheit
	12	Second
	13	Minute
	14	Hour
	15	Day
	16	Month
	17	Watt
	18	var
	19	VA
	20	Wh
	21	varh
	22	Vah
	23	Degree
	24	Hertz/second

7.1.5 Alarm assignments

Bit number	Description
0	Start alarm (relay 1)
1	Device error (relay 1)
2	Manual self test (relay 1)
3	AC residual current (relay 1)
4	DC residual current (relay 1)
5	RMS residual current (relay 1)
6...15	Reserved
16	Start alarm (relay 2)
17	Device error (relay 2)
18	Manual self test (relay 2)
19	AC residual current (relay 2)
20	DC residual current (relay 2)
21	RMS residual current (relay 2)
22...31	Reserved

7.1.6 Descriptions

Description	Value
Device error	115
DC fault current	155
AC fault current	156
RMS fault current	420
"inactive"	1021
"none"	1022
"invalid"	1023

7.2 Device information

Register	Property	Format	Description	Value/unit/comment	Factory settings
0...999		Reserved			
1000	RO	UINT32	Modbus test register	Is used to configure the interface (endianess, byte order, etc.)	0x12345678
1002	RO	String UTF-8	Device name	Maximum 32 characters (\0 = end character) Character is in the LoByte	Example: RCMB301\0
1034	RO	String UTF-8	Article number		Example: B74043122\0
1066	RO	String UTF-8	Serial number		

Register	Property	Format	Description	Value/unit/comment	Factory settings
1098	RO	String UTF-8	Manufacturer name	Maximum 96 characters (\0 = end character) Character is in the LoByte	Bender GmbH & Co. KG\0
1194	RO	UINT16	Application D number		579 (MRCDB3...) 610(RCMB3...)
1195	RO	UINT16	Application version	Version number multiplied by 100. Example: 123 = V1.23	
1196	RO	UINT16	Application Build number		
1197	RO	UINT16	Boot loader D number		605
1198	RO	UINT16	Boot loader version	Version number multiplied by 100. Example: 123 = V1.23	
1199	RO	UINT16	Boot loader Build number		
1200	RO	UINT32	Counter offset measurement	Counts how often complete, successful offset measurements were carried out.	
1202 - 1233	RO	String-UTF8	Internet address manufacturer ¹⁾	Character is in the LoByte in each case. Maximum 32 characters. \0 = NULL character = string end	www.bender.de\0
1234 - 1265	RW	String UTF-8	Installation location ²⁾		<location>\0
1266	RO	UINT16	Application Modbus module version	Version number x100 Example: 123= V1.23	
1267...3999		Reserved			

Tab. 7.1: Modbus register device information

Notes

- 1) Character is in the LoByte in each case. Maximum 32 characters. \0 = NULL character = string end.
- 2) Character is in the LoByte in each case. Maximum 32 characters. \0 = NULL character = string end. When writing this parameter, it must be ensured that the entire character string is structured in 8-character blocks and that one block must always be written completely with one Modbus command. This means that characters 1 to 8, 9 to 16, 17 to 24 and/or 25 to 32 must be written. If the string does not fill a block completely, it must be filled with NULL characters.
The installation location is also added to the server ID (function code 17) up to the first NULL character.

7.3 Detailed measured values

Register	Property	Format	Description		Value/unit
4000	RO	UINT16	AC	Measuring channel number (1)	
4001	RO	Float32		Residual current measured value (AC)	A
4003	RO	UINT16		Test and alarm status ¹⁾	
4004	RO	UINT16		Range and unit ²⁾	
4005	RO	UINT16		Description	
4006...4015	Reserved				
4016	RO	UINT16	DC	Measuring channel number (2)	
4017	RO	Float32		Residual current measured value (DC)	A
4019	RO	UINT16		Test and alarm status ¹⁾	
4020	RO	UINT16		Range and unit ²⁾	
4021	RO	UINT16		Description	
4022...4031	Reserved				
4032	RO	UINT16	RMS	Measuring channel number (3)	
4033	RO	Float32		Residual current measured value (RMS)	A
4035	RO	UINT16		Test and alarm status ¹⁾	
4036	RO	UINT16		Range and unit ²⁾	
4037	RO	UINT16		Description	
4038...4047	Reserved				
4048	RO	UINT16	Device error/status information	Measuring channel number (4)	
4049	RO	FLOAT32		Device error and status information ³⁾	Device/info code
4051	RO	UINT16		Test and alarm status ¹⁾	
4052	RO	UINT16		Range and unit ²⁾	
4053	RO	UINT16		Description	
4054...7999	Reserved				

Tab. 7.2: Detailed measured values

Notes

- 1) HiByte: Test status
LoByte: Alarm status
- 2) HiByte: Range
LoByte: Unit
- 3) see Table 7.4

7.4 General measured values

Register	Property	Format	Description	Unit Value Comment
8000	RO	Float32	Measured value $I_{\Delta n}$ (AC)	A
8002	RO	Float32	Measured value $I_{\Delta n}$ (DC)	A
8004	RO	Float32	Measured value $I_{\Delta n}$ (RMS)	A
8006	RO	Float32	Device error and status information ¹⁾	Device/info code
8008	RO	UINT32	Number of alarms	
8010	RO	Float32	Measured value $I_{\Delta n}$ (AC unfiltered)	A
8012	RO	Float32	Measured value $I_{\Delta n}$ (RMS unfiltered)	A
8014	RO	UINT32	Tripping status (alarm assignment that led to tripping)	Bit, binary coded HiWord: Relay 2 LoWord: Relay 1
8016	RO	Float32	Measured value $I_{\Delta n \max.}$ (AC) ²⁾	A
8018	RO	Float32	Measured value $I_{\Delta n \max.}$ (DC) ²⁾	A
8020	RO	Float32	Measured value $I_{\Delta n \max.}$ (RMS) ²⁾	A
8022	RO	Float32	Device error and status information ¹⁾²⁾	Device/info code
8024	RO	UINT32	Number of alarms ²⁾	-
8026	RO	Float32	Measured value $I_{\Delta n \max.}$ (AC unfiltered) ²⁾	A
8028	RO	Float32	Measured value $I_{\Delta n \max.}$ (RMS unfiltered) ²⁾	A
8030	RO	UINT32	Trigger status ²⁾	Bit, binary coded HiWord: Relay 2 LoWord: Relay 1
8032... 1200	Reserved			

Tab. 7.3: Simple measured values

Notes

- ¹⁾ see Table 7.4
- ²⁾ Same data as register 8000-8014, but the maximum values or cumulative values are output since the last readout.
In the case of the DC measured value, the highest value is stored.

7.4.1 Error codes

Error code	Error group	Error	Description	Action
0.10	Connection fault	Connection	CT connection faulty	Check connection between electronic box and measuring current transformer.
0.55		External circuit breaker	The present switching state of the external circuit breaker does not correspond to the target switching state.	Check circuit breaker and its cabling. Check contact feedback of the circuit breaker and its cabling. Parameter operating mode of the circuit breaker (Modbus register: 16056) and contact feedback
0.56		Shutdown control	Although the system is switched off, a (residual) current still flows.	Check circuit breaker and its cabling. Check parameter operating mode of the circuit breaker (Modbus register: 16056).
3.30	Component malfunction	Manual self test	The manual self test was not run without errors.	Check circuit breaker and its cabling. Check contact feedback of the circuit breaker and its cabling (if contact monitoring is active). Check parameter operating mode of the circuit breaker (Modbus register)
6.00	Calibration error			The error is deleted either by switching the device off/on or by performing a reset. The device restarts completely (switching of relays possible). If the error persists, return the device or contact Bender service.
6.10		No initial offset measurement	No offset measurement has been performed in the customer installation.	Perform offset measurement.
6.20		Offset measurement	Measured offset is outside the limits.	Does a (DC) current still flow through the measuring current transformer? Check circuit breaker. The error is deleted either by switching the device off/on or by performing a new offset measurement (if this is successful).
7.10	Internal interface error			If error occurs frequently, return the device or contact Bender service.
8.00 8.43 8.44 8.46 8.47 8.49 8.60 8.71	Hardware error			If error occurs frequently, return the device or contact Bender service.

Error code	Error group	Error	Description	Action
9.03	µC system error			Switch the device off and on again. If error persists, return the device or contact Bender service.
9.60		Parameter error	Parameter outside permissible limits	Switch the device off and on again. Reset device to factory settings: Modbus register 20007 or 20008. If error persists, return the device.
9.70				Switch the device off and on again. If error persists, return the device or contact Bender service.
9.90				Switch the device off and on again. If error persists, return the device or contact Bender service.

Tab. 7.4: Error codes

7.5 History

A maximum of 50 events can be stored. The events are sorted chronologically in such a way that the most recent event is number 1 and the oldest event is number 50.

The history memory is buffered and is only updated by reading register 12000 so that the sequence does not change during readout (due to a new history event).

The parameter "Overwrite history memory" (register: 16089) can be used to set

- whether the history memory fills to a maximum of 50 events and then has to be cleared manually (register: 20004)
- whether the oldest event (number 50) is overwritten automatically (factory setting).

Register	Property	Format	Description	Unit Value Comment
12000	RO	UINT16	Event 1 measuring channel number	1)
12001	RO	UINT32	Event 1 start	2)
12003	RO	UINT32	Event 1 end	
12005...12006		Reserved		
12007	RO	Float32	Event 1 min. value	
12009	RO	Float32	Event 1 max. value	
12011	RO	UINT16	Event 1 unit/test status	HiByte: Unit LoByte: Test status
12012	RO	UINT16	Event 1 alarm status min/max	HiByte: Min. value LoByte: Max. value
12013	RO	UINT16	Event 1 range min/max	
12014	RO	UINT16	Event 1 description	
12015...12017		Reserved		
12018...12035	RO		Event 2	
12036...12899	RO		Event 3...50	
12900...15999		Reserved		

1) When register 12000 is read out, the entire history memory is updated. This way, the data remains consistent.

2) If no time has been set in register 16084:
time in s from the occurrence of the event to the readout of register 12000
If a time is set in register 16084: UNIX time of the event.

7.6 Device parameters and factory settings

t_{on9} = response delay t_{off} = delay on release

Register	Property	Format	Description		Value range Unit {Step size}	Factory settings				
						MRCDB				RCMB
						301	302	303	304	301
16000	RW	Float32	AC	Limit value alarm	0.03...3.00 A {1 mA}	0.03 A	0.3 A	0.03 A	0.3 A	0.03
16002	RW			Limit value prewarning	50 ... 100 % {1 %}	60 %		50 %	60 %	
16004	RW			Hysteresis	10 ... 25 % {1 %}	15 %		25 %	15 %	
16006	RW			t_{on} alarm	MRCDB:	0 s				50 ms
16008	RW			t_{on} prewarning	0 s... 60 min	1 s		2 s	1 s	
16010	RW			t_{off} (pre)alarm	RCMB: 50 ms...60 min {10 ms}	1 s				
16012	RW	Float32	DC	Limit value alarm	0.03...3.00 A {1 mA}	0.03 A	0.3 A	0.03 A	0.3 A	0.03 A
16014	RW			Limit value prewarning	50 ... 100 % {1 %}	60 %		50 %		
16016	RW			Hysteresis	10 ... 25 % {1 %}	15 %		25 %	15 %	
16018	RW			t_{on} alarm	MRCDB:	0 s				50 ms
16020	RW			t_{on} prewarning	0 s... 60 min	1 s		2 s	1 s	
16022	RW			t_{off} (pre)alarm	RCMB: 50 ms...60 min {10 ms}	1 s				
16024	RW	Float32	RMS	Limit value alarm	0.03 ... 3.00 A {1 mA}	0.03 A	0.3 A	0.03 A	0.3 A	0.03 A
16026	RW			Limit value prewarning	50 ... 100 % {1 %}	60 %		50 %	60 %	
16028	RW			Hysteresis	10 ... 25 % {1 %}	15 %		35 %	15 %	
16030	RW			t_{on} alarm	MRCDB:	0 s (fixed)		0 s		50 ms
16032	RW			t_{on} prewarning	0 s... 60 min	1 s		2 s	1 s	
16034	RW			t_{off} (pre)alarm	RCMB: 50 ms...60 min {10 ms}	1 s				
16036	RW		Start-up delay	0 ... 3600 s {10 ms}	0 s					

Register	Property	Format	Description	Value range Unit {Step size}	Factory settings					
					MRCDB				RCMB	
					301	302	303	304	301	
16038	RW	UINT16	Relay 1	Relay mode	1 = N/C principle 2 = N/O principle	1				
16039	RW			Alarm assignment start alarm	Alarm assignment 1 = inactive 2 = active	2				
16040	RW			Alarm assignment device error		2				
16041	RW			Alarm assignment test		2 (fixed)				
16042	RW			Alarm assignment limit value violation $I_{\Delta n}$ prewarning (AC)		1				
16043	RW			Alarm assignment limit value violation $I_{\Delta n}$ prewarning (DC)		1				
16044	RW			Alarm assignment limit value violation $I_{\Delta n}$ prewarning (RMS)		2				
16045...16054				Reserved						
16055	RW	UINT16		Fault memory mode ¹⁾	1 = off 2 = on 3 = permanent	1				

Register	Property	Format	Description		Value range Unit (Step size)	Factory settings				
						MRCDB				RCMB
						301	302	303	304	301
16056	RW	UINT16	Relay 2	Relay mode	1 = N/C principle 2 = N/O principle	1			2	1
16057	RW			Alarm assignment start alarm	Alarm assignment 1 = inactive 2 = active	2 (fixed)		2		
16058	RW			Alarm assignment device error		2 (fixed)		2		
16059	RW			Alarm assignment test		2 (fixed)		2 (fixed)		
16060	RW			Alarm assignment limit value violation $I_{\Delta n}$ prewarning (AC)		1 (fixed)		1		
16061	RW			Alarm assignment limit value violation $I_{\Delta n}$ prewarning (DC)		1 (fixed)		1		
16062	RW			Alarm assignment limit value violation $I_{\Delta n}$ prewarning (RMS)		2 (fixed)		2		
16063...16072				Reserved						
16073	RW	UINT16		Fault memory mode	1 = off (only ...303 and ...304) 2 = on 3 = permanent	2		2	1	2
16074	RW	UINT16		Filter mode (Low-pass)	1)	10	12	4	3	4
16075	RW			Function contact monitoring ²⁾	1 = off 2 = N/C 3 = N/O	1				
16076	RW	Float32		t_{off} (contact monitoring) ²⁾	0 (= off) 0.01...3600 s Seconds Time delay after which the connected relay state is monitored. {10 ms}	0				

Register	Property	Format	Description		Value range Unit {Step size}	Factory settings				
						MRCDB				RCMB
						301	302	303	304	301
16078	RW	UINT16	Wired interface (RS-485)	Modbus address	1...247	Las 2 digits of the serial number + 100				
16079	RW	UINT32		Baud rate	1200 2400 4800 9600 19200 38400 57600	19200				
16081	RW	UINT16		Parity/stop bit	1 = 8N2 2 = 8O1 3 = 8E1 4 = 8N1 5 = 8O2 6 = 8E2	3				
16082			Reserved							
16084		UINT32	Time ³⁾	UNIX time ¹⁾	0 (when switching on the device)					
16086		Float 32	Time zone ³⁾	-12...+14 {0.25}	0 (when switching on the device)					
16088		UINT16	Summer time ³⁾	0 = off 1 = on 2 = CEST (Automat. switchover: Central Europe) 3 = DST (Automatic switchover: USA, CDN)	0 (when switching on the device)					
16089			Overwrite history memory	1 = do not overwrite 2 = overwrite automatically	2					
16090... 19999			Reserved							

Notes:

- 1) Register 16074 "Filter mode"

Register entry	Meaning	Adjustable for			
		MRCDB 301	MRCDB 302	MRCDB 303	MRCDB 304
1	Normal (full bandwidth: 100 kHz)	X	X	X	X
2	Low-pass 60 Hz	—	—	X	X
3	Low-pass 500 Hz	—	—	X	X
4	Low-pass 1 kHz	X	—	X	X
5	Low-pass 2 kHz	X	—	X	X
6	Low-pass 5 kHz	X	—	X	X
7	Low-pass 10 kHz	X	—	X	X
8	Low-pass 20 kHz	X	X	X	X
9	Low-pass 50 kHz	X	X	X	X
10	Type B	X	—	X	X
11	Reserved				
12	Type B+ (up to 100 kHz)	—	X	X	X
13	Reserved				
14	Fire protection (up to 100 kHz)	—	—	X	X
15...16	Reserved				
17	Low-pass 180 Hz	—	—	X	X

- 2) Registers 16075 and 16076: If contact monitoring is active, the **disconnected** state is always checked after 500 ms (not configurable). If and when the **connected** state is checked depends on register 16076.
- 3) Is not saved when the device is switched off.

7.7 Control commands

Register	Property	Format	Description	Comment Unit Value	Factory setting
20000	RW	UINT16	Device test	Manual device tripping test. Same behaviour as test button. Read 1 = test inactive/completed 2 = test running Write 2 = start test	1
20001	WO	UINT16	Device reset	Deleting fault and alarm messages. Same behaviour as reset button. 1 = perform reset	
20002	RW	UINT16	Relay 1 test	1 = test inactive (normal function) 2 = relay energised 3 = relay de-energised	1
20003	RW	UINT16	Relay 2 test	Switches automatically back to 1 = test inactive after one minute at the latest.	1
20004	WO	UINT16	Clear history memory	1 = perform deletion (secured via reg. 12005)	
20005	RW	UINT16	Allow register write access	Flag to allow changing important registers. Is automatically deactivated after five seconds. 1 = deny 2 = allow	1
20006	RW	UINT16	Activate device signalling	Makes the LED flash quickly red and green in alternation to detect the device in its environment faster. Is automatically deactivated after one minute. 1 = inactive; 2 = active	1
20007	WO	UINT16	Load factory settings (without interface)	Loads all factory settings except the interface parameters. Secured via register 20005. 1 = restore factory settings	
20008	WO	UINT16	Load factory settings (all parameters)	Loads all factory settings including the interface parameters. Secured via register 20005. 1 = restore factory settings	
20009	RW	UINT16	Start offset measurement	Read 1 = offset measurement inactive/completed 2 = offset measurement running Write 2 = start offset measurement (secured via reg. 12005)	1

Register	Property	Format	Description	Comment Unit Value	Factory setting
20010	RW	UINT16	Test alarm ¹⁾	0 = no test alarm 1 = test alarm channel 1 2 = test alarm channel 2 3 = test alarm channel 3 4 = test alarm channel 4	0
20011...23999		Reserved			

Tab. 7.5: Control commands

- ¹⁾ Test alarm: Output a test alarm on a measuring channel. The test alarm refers only to bus messages. No relays switch. The test alarm is deactivated after 1 minute (= 0).

7.8 Additional function codes:

7.8.1 Diagnostic (function code 0x08)

Sub-function code name	Sub-function code number (decimal)	Error counter	Supported	Notes
Return Query Data	0		X	
Restart Communication	1		X	
Return Diagnostic Register	2		X	1)
Change ASCII Input Delimiter	3			
Force Listen Only Mode	4		X	
Reserved	5...9			
Clear Counters and Diagnostic Register	10		X	
Return Bus Message Count	11		X	
Return Bus Communication Error Count	12	X	X	2)
Return Bus Exception Error Count	13	X	X	
Return Server Message Count	14		X	
Return Server No Response Count	15		X	
Return Server NAK Count	16	X	X	
Return Server Busy Count	17	X	X	
Return Bus Character Overrun Count	18	X	X	
Reserved	19			
Clear Overrun Counter and Flag	20		X	
Reserved	21...65535			

Tab. 7.6: Additional function codes: Diagnostic

- 1) The diagnostic register is 0 if all error counters are 0. Otherwise it is 1.
 2) It is a 16-bit counter. This means that a maximum of 65535 is counted. There is no overflow.

7.8.2 Get Com Event Counter (function code 0x0B)

Response	Notes
Status	If a previously received command is still being processed, then the answer is 0xFFFF. Otherwise it is 0x0000. (Current implementation: always 0x0000).
Event Count	It is a 16-bit counter. This means that a maximum of 65535 is counted. There is no overflow.

Tab. 7.7: Get Com event Counter

7.8.3 Report Server ID (function code 0x11)

Response	Notes	
Byte count	Number of bytes from "Server ID" to "Installation location"	
Server ID	Is always 0x01.	
Run Indicator Status	Is always 0xFF.	
Manufacturer name	Same information as register 1098.	Output as ASCII string.
Device name	Same information as register 1002.	
Application D number	Same information as register 1194.	
Application version	Same information as register 1195.	
Application Build number	Same information as register 1196.	
Installation location	Same information as register 1234.	

Tab. 7.8: Report Server ID

7.8.4 Device Identification (function code 0x2B)

Object ID	Object name / Description	Data type	Category	Supported	Notes
0x00	Manufacturer name	ASCII string	Basic	X	Corresponds to register 1098
0x01	Article number			X	Corresponds to register 1034
0x02	Application software, version and build number			X	Corresponds to registers 1194, 1195 and 1196
0x03	Internet address manufacturer	ASCII string	Regular	X	Corresponds to register 1202
0x04	Device name			X	Corresponds to register 1002
0x05	Model name				
0x06	User application name				
0x07... 0x7F	Reserved				
0x80... 0xFF	Non-public objects		Extended		

Tab. 7.9: Device Identification

8. System states: LED and output relays

The LED indicates the system state by means of colours and lighting/flashing. The N/O contacts of relay outputs K1 and K2 have defined switching positions for each system state.

System state	GREEN LED ON	RED LED Alarm	Notes	Changeover contact K1	Changeover contact K2
Device switched off	Off	Off	Device is de-energised, no monitoring, no monitoring function	De-energised	De-energised
Normal operating state	Lights	Off	The device is supplied with the specified voltage and monitors the primary circuit. No residual current flows which would lead to tripping.	Energised	Energised
Prewarning	Lights	Flashes briefly	The device is supplied with the specified voltage and monitors the primary circuit. A fault current flows which exceeds the set limit of the prewarning.	De-energised	Energised
Alarm state	Off	Lights	The device is supplied with the specified voltage and monitors the primary circuit. A fault current flows which exceeds the set limit of the alarm.	De-energised	De-energised
Device error	Off	Flashes slowly	The device is supplied with the specified voltage and monitors the primary circuit. An error is detected by the periodic self tests.	De-energised	De-energised
Device in calibration mode	Offset calibration procedure: see page 29			De-energised	De-energised
Device in address mode	For procedure, refer to page 27				
Device signalling	Flash quickly in alternation		Use Modbus register 20006 = 2 to detect the device in its environment faster. Is automatically deactivated after one minute.		

Tab. 8.1: System states: LED and output relays

9. Frequency responses

9.1 Low passes LP

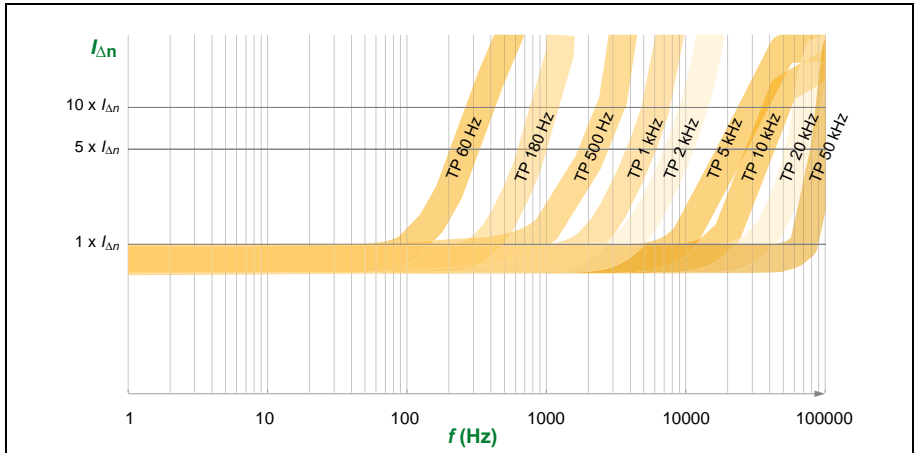

9.2 Type B+

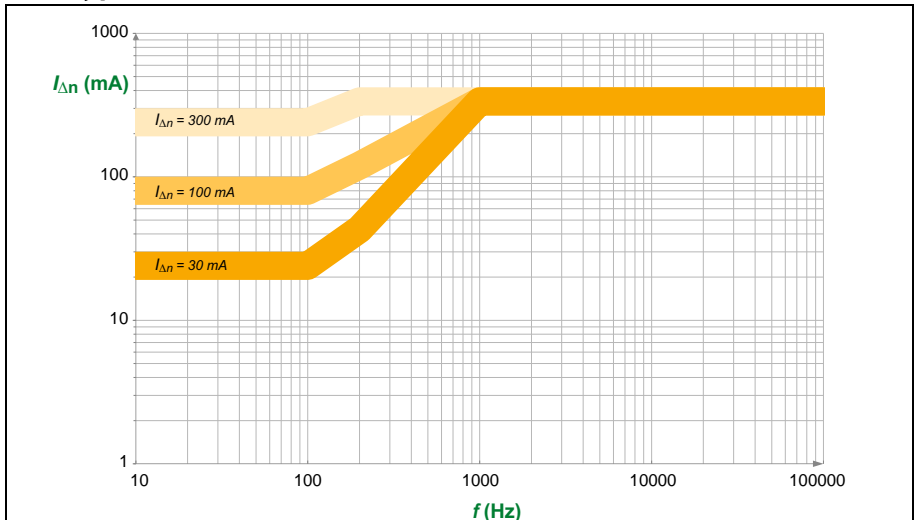

9.3 Type B

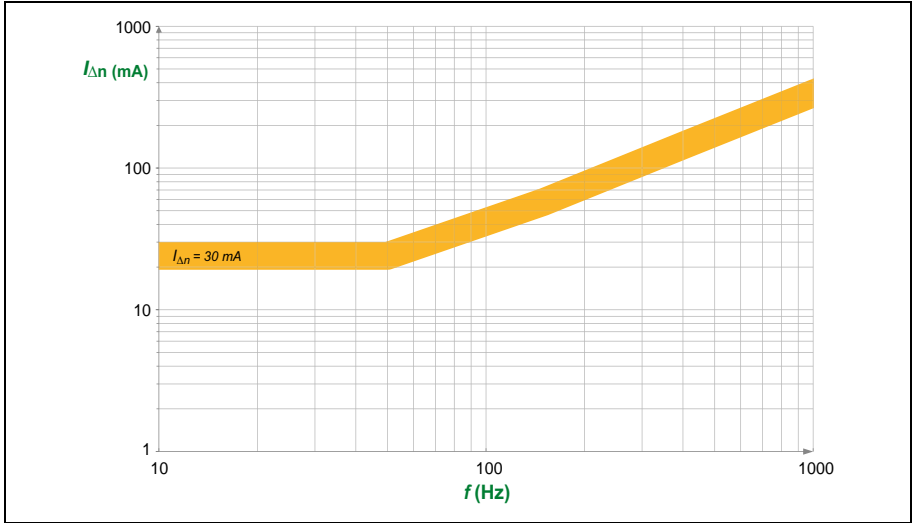

9.4 Fire protection 100 kHz

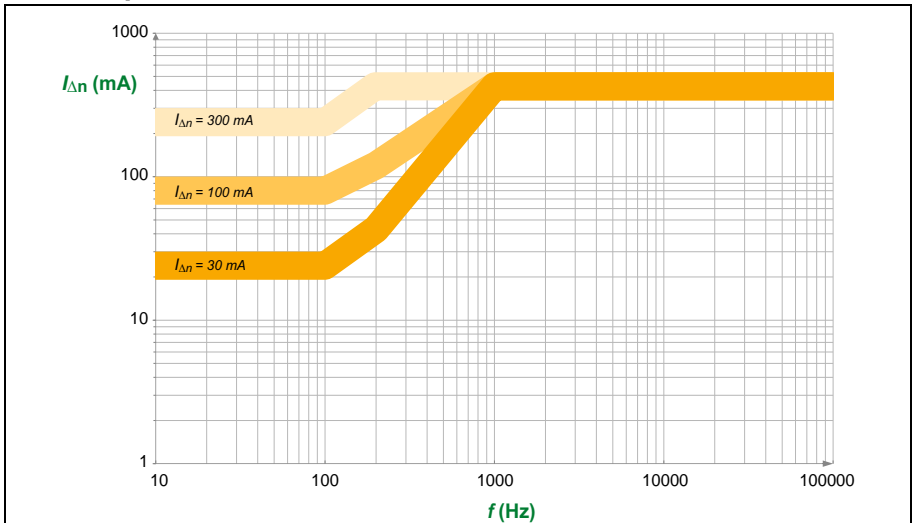

10. Technical data

10.1 Tabular data

Insulation coordination acc. to IEC 60664-1/IEC 60664-3

Definitions

Measuring circuit (IC1)	Primary conductors routed through the current transformer
Secondary (IC2)	Terminal block 1 (24 V, GND, D1, DG, T/R, GND, A, B, X1, X2)
Control circuit 1 (IC3)	Terminal block 1 (11,12,14)
Control circuit 2 (IC4)	Terminal block 2 (21,22,24)
Rated insulation voltage.....	800 V
Overtoltage category.....	III
Area of application	≤ 2000 m AMSL

Rated impulse voltage

IC1/(IC2-IC4)	8 kV
IC2/(IC3-IC4)	4 kV
IC3/IC4	4 kV

Rated insulation voltage

IC1/(IC2-IC4)	800 V
IC2/(IC3-IC4)	250 V
IC3/IC4	250 V

Pollution degree..... 2

Safe isolation (reinforced insulation) between

IC2/(IC3-IC4)	300 V
---------------------	-------

Basic insulation between:

IC1/(IC2-IC4)	800 V
IC3/IC4	300 V

Voltage tests (routine test) acc. to IEC 61010-1

IC2/(IC3-IC4).....	AC 2.2 kV
IC3/IC4.....	AC 2.2 kV

Supply voltage

Supply voltage U_S	DC 24 V
Operating range of U_S	±20 %
Ripple U_S	≤ 1 %
Power consumption.....	≤ 2.5 W
Inrush current	1.7 A for 1 ms

Measuring circuit

Internal diameter measuring current transformer	see dimension diagrams page 18
Characteristics according to IEC 62020 and IEC/TR 60755	AC/DC sensitive, type B
Response value $I_{\Delta n}$	see frequency responses from page 53
MRCDB301 (protection of persons)	30 mA
MRCDB302 (fire protection)	300 mA
MRCDB303	30 mA . . . 3 A (freely configurable)
MRCDB304 (plant protection)	300 mA
Rated current I_n	
CTBC20 when $I_{\Delta n} = 30$ mA	40 A
CTBC20 when $I_{\Delta n} = 300$ mA	63 A
CTBC20P	80 A
CTBC35 when $I_{\Delta n} = 30$ mA	80 A
CTBC35 when $I_{\Delta n} = 300$ mA	125 A
CTBC35P	160 A
CTBC60 when $I_{\Delta n} = 30$ mA	160 A
CTBC60 when $I_{\Delta n} = 300$ mA	250 A
CTBC60P	320 A
CTBC120 when $I_{\Delta n} = 100$ mA	330 A
CTBC120P when $I_{\Delta n} = 100$ mA	630 A
CTBC210 when $I_{\Delta n} = 300$ mA	630 A
CTBC210P when $I_{\Delta n} = 100$ mA	630 A
CTBC210P when $I_{\Delta n} = 300$ mA	1000 A
Operating uncertainty	± 17.5 %
Relative uncertainty	0 . . . -35 %
Test winding	yes

Possible response values (to be set on the evaluator)

CTBC20, CTBC20P	10 . . . 500 mA
CTBC35, CTBC35P, CTUBC60, CTBC60P	30 mA . . . 10 A
CTBC120P, CTBC210P	100 mA . . . 10 A
CTBC120, CTBC210	300 mA . . . 10 A

Time response

Response delay t_{0n}	
MRCDB301, MRCDB302	0 s
MRCDB303	0 s . . . 60 min (freely configurable), (0 s)*
Start-up delay t_{an}	0 s . . . 60 min (freely configurable), (0 s)*
Delay on release t_{off}	2 s after reset

Operating time t_{ae}	
at $1 \times I_{\Delta n}$	≤ 180 ms
at $2 \times I_{\Delta n}$	≤ 130 ms
at $5 \times I_{\Delta n}$	≤ 20 ms
Response time $t_{an} = t_{ae} + t_{on}$	
Recovery time t_b	≤ 1 s

Indication

Multicolour LED	red/green
-----------------------	-----------

Inputs

.....	T/R, GND, D1, DG
-------	------------------

Outputs

Number of changeover contacts	2
Operating principle	
MRCDB301, MRCDB302	N/C principle
MRCDB303	N/C principle*/N/O principle, *freely configurable
MRCDB304	N/O principle
Switching outputs (K1, K2)	250 V, 5 A
Switching capacity.....	1500 VA/144 W
Contact data acc. to IEC 60947-5-1	
Rated operational voltage AC	250 V/250 V
Utilisation category	AC-13/AC-14
Rated operational current AC	5 A/3 A
Rated operational current AC (for UL applications)	3 A/3 A
Rated operational voltage DC.....	220/110/24 V
Utilisation category.....	DC12
Rated operational current DC	0.1/0.2/1 A
Minimum current.....	10 mA at DC 5 V
Electrical endurance, number of cycles.....	10,000

Environment/EMC

EMC	IEC 60947-2 Annex M
Operating temperature.....	-25...70 °C
Classification of climatic conditions acc. to IEC 60721	
Stationary use (IEC 60721-3-3)	3K5 (except condensation and formation of ice)
Transport (IEC 60721-3-2)	2K11 (except condensation and formation of ice)
Long-term storage (IEC 60721-3-1)	1K22 (except condensation and formation of ice)

Classification of mechanical conditions acc. to IEC 60721

Stationary use (IEC 60721-3-3)	3M4
Transport (IEC 60721-3-2)	2M4
Long-term storage (IEC 60721-3-1)	1M12

Connection

Required terminals are included in the scope of delivery (except MRCDB304).

Terminal block 1

Manufacturer	Phoenix Contact
Type	DFMC 1.5/5-ST-3.5 BK

The connection conditions of the manufacturer apply.

Connection properties

rigid	0.2 ... 1.5 mm ² (AWG 24 ... 16)
flexible	0.2 ... 1.5 mm ² (AWG 24 ... 16)
with ferrules	0.25 ... 0.75 mm ² (AWG 24 ... 19)

Terminal block 2, 3

Manufacturer	Phoenix Contact
Type	FKCVW 2.5/3-ST-5.08

The connection conditions of the manufacturer apply.

Connection properties

rigid	0.2 ... 2.5 mm ² (AWG 24 ... 13)
flexible	0.2 ... 2.5 mm ² (AWG 24 ... 13)
with ferrules	0.25 ... 2.5 mm ² (AWG 24 ... 13)

Mounting CTBC...

Screw type

CTBC20 ... 60(P)	DIN EN ISO 7045 - M5
CTCB120 ... 210(P)	DIN EN ISO 7045 - M6

Washer type

CTBC20 ... 60(P)	DIN EN ISO 7089/7090 - 5
CTCB120 ... 210(P)	DIN EN ISO 7089/7090 - 6

Tightening torque

CTBC20 ... 35 (P)	0.6 Nm
CTCB60 ... 210(P)	1 Nm

Other

Operating mode continuous operation

Mounting any position

Degree of protection, internal components (DIN EN 60529) IP40

Degree of protection, terminals (DIN EN 60529) IP20

Flammability class	UL94 V-0
Software	D0579 V1.4x
Weight	
MRCDB30	≤ 100 g
CTBC20	≤ 160 g
CTBC20P	≤ 220 g
CTBC35	≤ 240 g
CTBC35P	≤ 320 g
CTBC60	≤ 460 g
CTBC60P	≤ 620 g
CTBC120	≤ 1390 g
CTBC120P	≤ 1750 g
CTBC210	≤ 4220 g
CTBC210P	≤ 4870 g

10.2 Standards and certifications



10.3 Ordering details

10.3.1 Electronic modules

Supply voltage	Variant	Type	Art. No.
DC 24 V (19.2 . . . 28.8 V)	Protection of persons	MRCDB301	B74043120
	Fire protection	MRCDB302	B74043121
	Protection of persons, fire protection and plant protection (freely configurable)	MRCDB303	B74043122
	Plant protection	MRCDB304	On request

10.3.2 Measuring current transformers

Type	Description	Art. No.
CTBC20	Measuring current transformer, internal diameter 20 mm	B98120001
CTBC20P	Measuring current transformer shielded, internal diameter 20 mm	B98120002
CTBC35	Measuring current transformer, internal diameter 35 mm	B98120003
CTBC35P	Measuring current transformer shielded, inside diameter 35 mm	B98120004
CTBC60	Measuring current transformer, inside diameter 60 mm	B98120005
CTBC60P	Measuring current transformer shielded, inside diameter 60 mm	B98120006
CTBC120	Measuring current transformer, internal diameter 120 mm	B98120007
CTBC120P	Measuring current transformer shielded, internal diameter 120 mm	B98120020
CTBC210	Measuring current transformer, internal diameter 210 mm	B98120008
CTBC210P	CTBC210P Measuring current transformer shielded, internal diameter 210 mm	B98120021

10.3.3 Accessories

Description	Art. No.
USB to RS-485 interface converter	B95012045
Terminal set for MRCD module (for MRCD301...MRCD303 included in scope of delivery)	B74043124

10.3.4 Suitable system components

Description	Max. number of current transformers	Type	Art. No.
Voltage supply	4	STEP-PS/1 AC/24 DC/0.5	B94053110
	14	STEP-PS/1 AC/24 DC/1.75	B94053111
	34	STEP-PS/1 AC/24 DC/4.2	B94053112

INDEX

A

Address setting 27
Application example 16
Area of application 13
Assembly 19

B

Bending cables 26

D

DC calibration 29
Device features 13
Device view MRCDB30... 20
Dimension diagram 18
Disposal 10

E

External test/reset button 31

F

Function test 30, 32
Functional description 16

H

How to use this manual 7

I

Installation 17
Intended use 11

L

LED 51

M

Manual self test 31
Modbus RTU 25
Mountings CTBC... 19

N

N/C principle 21
N/C principle (with contact feedback) 22
N/O principle 23, 24

O

Output relays 51

P

Periodic self test 31
Protective conductors and live conductors 26

R

Route-through direction 26
Routing cables centrally 26

S

Service 7
Setpoints 14
Support 7
System states 7, 26, 51, 53

T

Technical data 51
Training courses 8

V

Versions 14

W

Work activities on electrical installations 11
Workshops 8



All rights reserved.
Reprinting and duplicating
only with permission of the publisher.

Bender GmbH & Co. KG
P.O. Box 1161 • 35301 Grünberg • Germany
Londorfer Str. 65 • 35305 Grünberg • Germany
Tel.: +49 6401 807-0 • Fax: +49 6401 807-259
E-Mail: info@bender.de • www.bender.de



Photography: Bender Archive