

WS50x80S...WS80x160S

Measuring current transformers

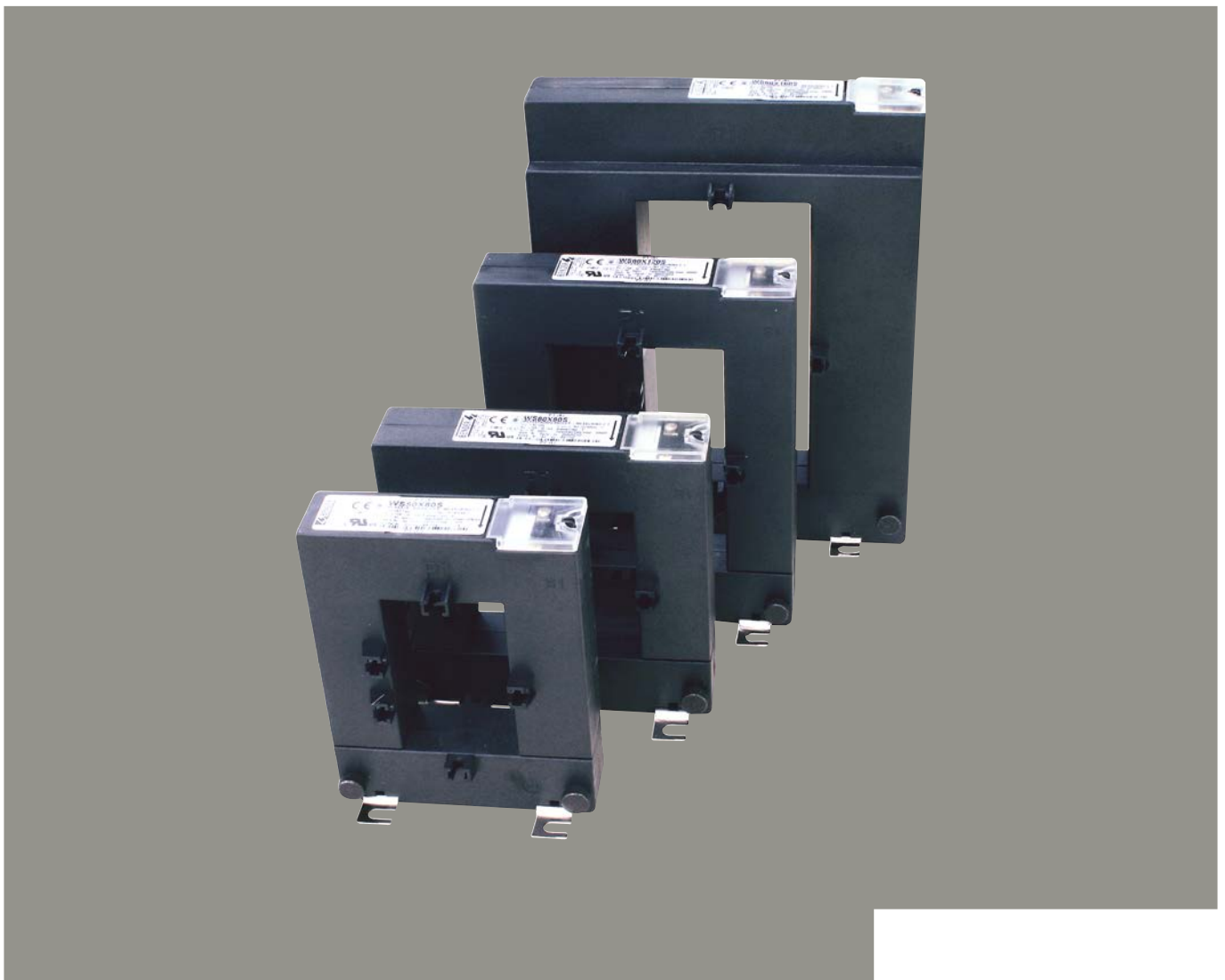



Measuring current transformers WS50x80S



Measuring current transformers WS80x160S

Product description

The highly sensitive split-core-type WS... series measuring current transformers convert residual currents of 10 mA...100 A into evaluable RCM signals and can be retrofitted to existing electrical installations where disconnection must be prevented. The CTs are connected to the respective evaluator by two wires. Depending on the connecting lead used, the distance between the CT and the evaluator may be up to 40 m.

Make sure that all live conductors are routed through the measuring current transformer and that these conductors are not shielded.

Never route a PE conductor through the measuring current transformer!

Application

- For residual current monitors (RCM)
- For residual current monitoring systems (RCMS)

Standards

WS... measuring current transformers comply with the device standards:

- IEC 60044-1

Approvals



Ordering information

Type	Internal dimensions	Approvals		Art. No.
		UL	LR	
WS50x80S	50 x 80 mm	■	■	B911741
WS80x80S	80 x 80 mm	■	■	B911742
WS80x120S	80 x 120 mm	■	■	B911743
WS80x160S	80 x 160 mm	–	■	B911755

Technical data

Insulation coordination acc. to IEC 60044-1

Highest system voltage for electrical equipment U_m	AC 720 V
Rated impulse withstand voltage U_{iso}	3 kV

Measuring circuit

Rated transformation ratio	600/1
Rated burden	180 Ω
Rated primary current	≤ 10 A (100 A) ≥ 10 mA
Nominal power	50 mVA
Rated frequency	50...400 Hz
Internal resistance	5...8 Ω
Secondary overvoltage protection	with suppressor diode P6KE6V8CP
Accuracy class	5
Rated continuous thermal current	100 A
Rated short-time thermal current	14 kA/1 s
Rated dynamic current	35 kA/30 ms

Environment

Shock resistance IEC 60068-2-27 (device in operation)	15 g/11 ms
Bumping IEC 60068-2-29 (transport)	40 g/6 s
Vibration resistance IEC 60068-2-6	
device in operation	1 g/10...150 Hz
transport	2 g/10...150 Hz
Ambient temperature	
during operation	-10...+50 °C
storage temperature range	-40...+70 °C
Climatic class acc. to DIN IEC 60721-3-3	3K22

Connection

Connection	screw-type terminals
Connection	
rigid/flexible	0.2...4/0.2...2.5 mm ²
flexible with ferrules with/without plastic sleeve	0.25...2.5 mm ²
Conductor sizes (AWG)	24...12
Connection to the evaluator	
single wire ≥ 0.75 mm ²	0...1 m
single wire, twisted ≥ 0.75 mm ²	0...10 m
shielded cable ≥ 0.6 mm ²	0...40 m
Shielded cable (shield on one side connected to PE)	recommended: J-Y(St)Y min. 2 x 0.6

Other

Operating mode	continuous operation
Mounting	any position
Degree of protection	
internal components (DIN EN 60529)	IP40
terminals (DIN EN 60529)	IP20
Screw mounting	M5
Flammability class	UL94 V-0
Documentation number	D00145

Dimensions (mm) and weights (g)

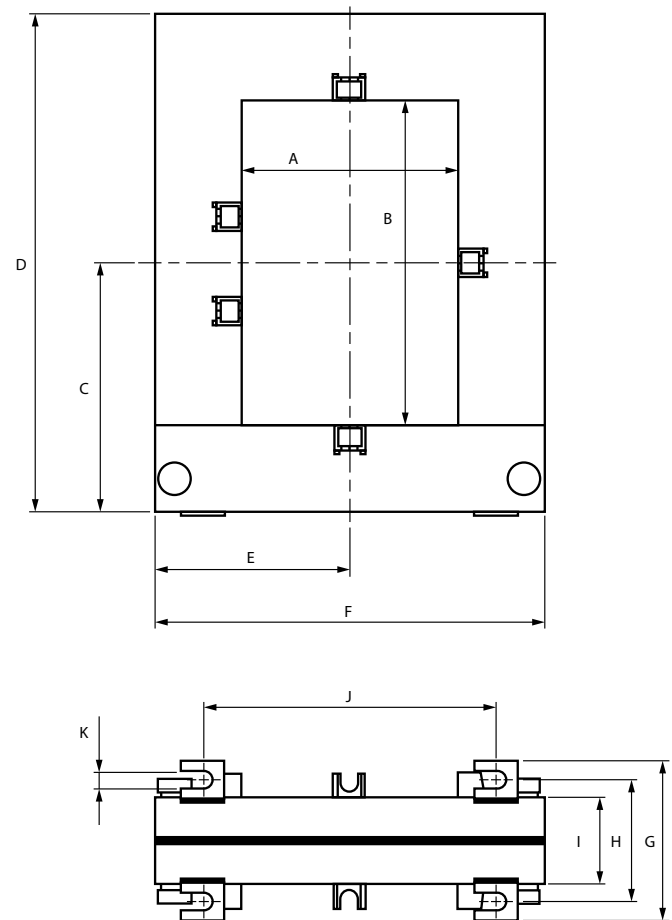

Type	Dimensions (mm)											Weight
	A	B	C	D	E	F	G	H	I	J	K	
WS50x80S	50	80	72	145	57	114	59	45	32	78	6.5	900 g
WS80x80S	80	80	72	145	72	144	59	45	32	108	6.5	1050 g
WS80x120S	80	120	92	184	72	144	59	45	32	108	6.5	1250 g
WS80x160S	80	160	113	246	92	184	59	45	32	120	6.5	2550 g

Installation instructions

- Do not pass shielded cables through the measuring current transformer.
- As a general principle, the PE conductor and low-resistance conductor loops must not be passed through the measuring current transformer!

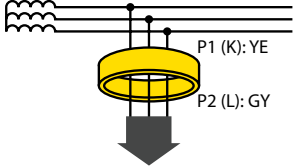
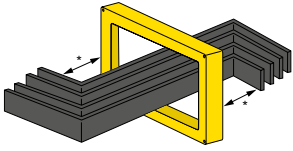
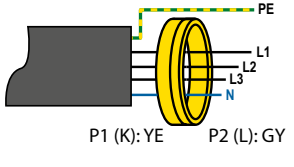
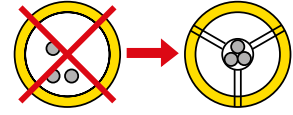
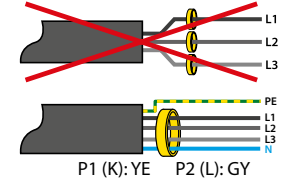
<p>It is important that the leads are passed through the measuring current transformer in the right direction</p>		<p>The primary conductors may only be bent from the specified minimum distance. The minimum bending radius specified by the manufacturers must be observed. * Distance to 90° angle: 2x external diameter of the current transformer</p>	
<p>Never pass a PE conductor through the measuring current transformer</p>		<p>The leads must be aligned with the centre of the measuring current transformer</p>	
<p>Make sure that all current-carrying leads are passed through the measuring current transformer</p>			



Bender GmbH & Co. KG

Londorfer Straße 65
35305 Grünberg
Germany

Tel.: +49 6401 807-0
info@bender.de
www.bender.de



© Bender GmbH & Co. KG, Germany
Subject to change!
The specified standards take into account the edition valid until 03.2026 unless otherwise indicated.