Isolating transformer ES710...-E

Single-phase isolating transformers for the design of medical IT systems



Isolating transformer ES710...-E

Single-phase isolating transformers
for the design of medical IT systems



Device features

- Built-in temperature sensors acc. to DIN 44081 (120 °C)
- Screen winding with brought-out insulated connection terminal
- Insulated mounting angles
- Degree of protection, IP00
- Protection class I
- Reinforced insulation
- Classification of insulation: t_a40/F
- Connections: screw terminals
- Noise level < 35 dB (A) (no-load and nominal load)
- Vector group: liO

Approvals



Application and description

The transformers of the ES710...-E series have reinforced insulation and comply with the requirements of IEC 61558-1/DIN EN 61558-1 (VDE 0570-1) and IEC 61558-2-15/DIN EN 61558-2-15 (VDE 0570-2-15).

In addition, the transformers comply with the requirements of IEC 60364-7-710/DIN VDE 0100-710 (VDE 0100-710) for IT systems in medical locations. The windings are galvanically isolated. In order to minimize electrical interferences, an electrostatic screen is installed between the primary and secondary winding the lead out of which is connected to an insulated terminal for connection to the equipotential bonding.

The fixing angles are isolated from the transformer core in order to guarantee an isolated installation to comply with the requirements of DIN VDE 0100-710 (VDE 0100-710), para. 710.512.1.101.

The transformers are available for horizontal installation. Protection against corrosion is guaranteed by a complete resin impregnation.

The transformers are designed for use in dry locations.

Frequency/ratings

The transformers are designed for rated frequencies of 50...60 Hz. The values specified in the chapter "Technical data" refer to a maximum ambient temperature of 40 °C and a rated frequency of 50 Hz.

Temperature rise

Free air circulation must be ensured. An ambient temperature exceeding 40 °C will reduce the rated power. For temperature monitoring, a PTC thermistor is placed on each transformer leg and the leads are connected to the terminals.

Rated power

According to DIN VDE 0100-710 (VDE 0100-710), the rated power of the transformer shall not be less than 3.15 kVA and shall not exceed 8 kVA.

Overload protection

When isolating transformers are used to form a medical IT system in accordance with para. 710.512.1.6.2 of DIN VDE 0100-710 (VDE 0100-710), **overload protection is not permitted**. In this case, short-circuit protection is required. That means, emphasis is focused on the availability of the power supply; it is therefore essential to avoid disconnection on the occurrence of transient overload. The protection of isolating transformers against overload and overtemperature can be realized by using monitoring devices in accordance with para. 710.531.3.1. The appropriate fuses for short-circuit protection can be selected from the table "Technical data".

Standards

ES710...-E isolating transformers comply with the device standards and the regulations for installation:

- DIN EN 61558-1 (VDE 570-1)
- IEC 61558-1
- DIN VDE 0100-710 (VDE 0100-710)
- DIN EN 61558-2-15 (VDE 0570-2-15)
- IEC 61558-2-15
- IEC 60364-7-710

Nameplate

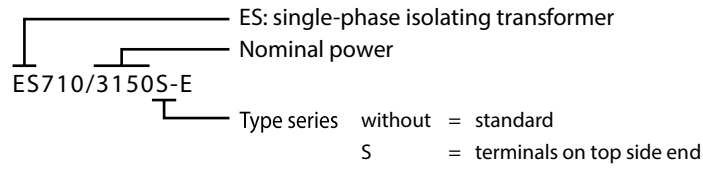

Wiring diagram

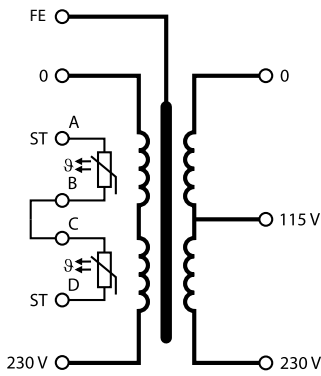

Terminal diagram

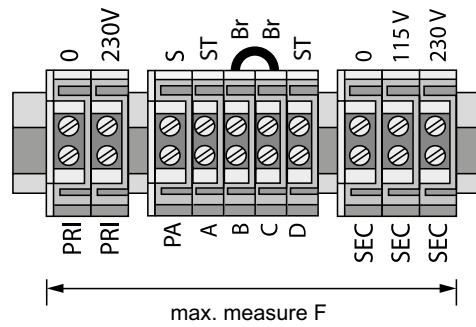

Connection properties

Type	Input terminals flexible/rigid	Screen winding flexible/rigid	Control terminals flexible/rigid	Output terminals flexible/rigid
ES710/3150-E	16/25 mm ²	16/25 mm ²	4/6 mm ²	16/25 mm ²
ES710/4000-E	16/25 mm ²	16/25 mm ²	4/6 mm ²	16/25 mm ²
ES710/5000-E	16/25 mm ²	16/25 mm ²	4/6 mm ²	16/25 mm ²
ES710/6300-E	16/25 mm ²	16/25 mm ²	4/6 mm ²	16/25 mm ²
ES710/8000-E	16/25 mm ²	16/25 mm ²	4/6 mm ²	16/25 mm ²
ES710/10000-E	35/35 mm ²	35/35 mm ²	4/6 mm ²	35/35 mm ²

Dimension diagram/type of construction

Standard

Dimension B is the depth incl. terminals

S series

Dimension E is the depth incl. terminals

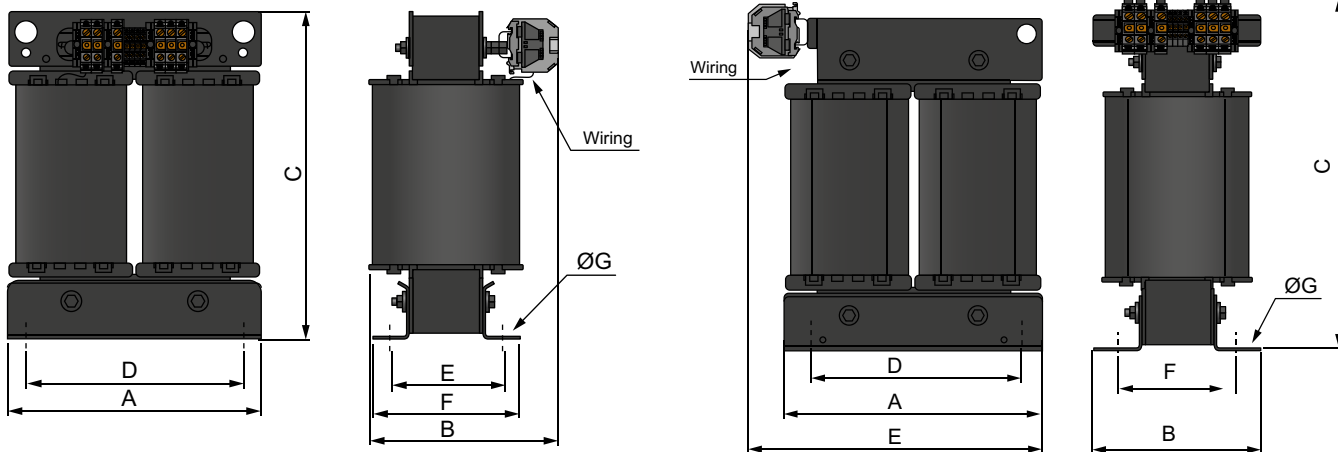

Ordering information

	Dimensions (mm)							Cu weight (kg)	Weight (kg)	Core U/I	Type	Art. No.
	A	B	C	D	E	F	G					
Standard	240	212	310	200	145	180	11 x 28	11	42.5	180/78	ES710/3150-E	B92090101
	280	190	361	240	115	150	11 x 28	14	45	210/63	ES710/4000-E	B92090102
	280	205	361	240	125	160	11 x 28	16	52	210/73	ES710/5000-E	B92090103
	280	220	361	240	140	175	11 x 28	18	62	210/88	ES710/6300-E	B92090104
	280	235	361	240	155	190	11 x 28	24	76	210/103	ES710/8000-E	B92090105
	320	250	415	270	191	231	13 x 18	30	88	240/83	ES710/10000-E	B92090106
S series	240	180	370	200	255	145	11 x 28	11	42.5	180/78	ES710/3150S-E	B92090111
	280	150	375	240	325	115	11 x 28	14	45	210/63	ES710/4000S-E	B92090112
	280	160	375	240	325	125	11 x 28	16	52	210/73	ES710/5000S-E	B92090113
	280	175	375	240	325	140	11 x 28	18	62	210/88	ES710/6300S-E	B92090114
	280	190	375	240	325	155	11 x 28	24	76	210/103	ES710/8000S-E	B92090115
	320	205	435	262	365	149	13 x 18	30	88	240/83	ES710/10000S-E	B92090116

Technical data

Type	ES710/3150-E	ES710/4000-E	ES710/5000-E	ES710/6300-E	ES710/8000-E	ES710/10000-E
Power/voltages/currents						
Rated power	3150 VA	4000 VA	5000 VA	6300 VA	8000 VA	10000 VA
Rated frequency	50...60 Hz	50...60 Hz	50...60 Hz	50...60 Hz	50...60 Hz	50...60 Hz
Rated input voltage	AC 230 V	AC 230 V	AC 230 V	AC 230 V	AC 230 V	AC 230 V
Rated input current	14.2 A	18 A	22.5 A	28.5 A	36.1 A	45.2 A
Rated output voltage	AC 230/115 V	AC 230/115 V	AC 230/115 V	AC 230/115 V	AC 230/115 V	AC 230/115 V
Rated output current	13.7 A	17.4 A	21.7 A	27.4 A	34.8 A	43.5 A
Inrush current I_E	$< 12 \times \hat{I}_n$	$< 12 \times \hat{I}_n$	$< 12 \times \hat{I}_n$	$< 12 \times \hat{I}_n$	$< 12 \times \hat{I}_n$	$< 12 \times \hat{I}_n$
Leakage current	≤ 0.5 mA	≤ 0.5 mA	≤ 0.5 mA	≤ 0.5 mA	≤ 0.5 mA	≤ 0.5 mA
No-load input current i_0	≤ 3 %	≤ 3 %	≤ 3 %	≤ 3 %	≤ 2.8 %	≤ 3 %
No-load output voltage U_0	≤ 238 V	≤ 238 V	≤ 235 V	≤ 235 V	≤ 237 V	≤ 237 V
Short-circuit voltage U_k ca.	≤ 4.4 %	≤ 4 %	≤ 3.7 %	≤ 2.8 %	≤ 2.8 %	≤ 3.3 %
Environmental conditions						
Ambient temperature	≤ 40 °C	≤ 40 °C	≤ 40 °C	≤ 40 °C	≤ 40 °C	≤ 40 °C
No-load temperature rise	≤ 22 °C	≤ 22 °C	≤ 26 °C	≤ 31 °C	≤ 33 °C	≤ 36 °C
Full-load temperature rise	≤ 55 °C	≤ 53 °C	≤ 62 °C	≤ 67 °C	≤ 76 °C	≤ 65 °C
Noise level (under no-load conditions and nominal load)	≤ 35 dB(A)	≤ 35 dB(A)	≤ 35 dB(A)	≤ 35 dB(A)	≤ 35 dB(A)	≤ 35 dB(A)
Other						
Insulation classification	t_a40/F	t_a40/F	t_a40/F	t_a40/F	t_a40/F	t_a40/F
Degree of protection	IP00	IP00	IP00	IP00	IP00	IP00
Protection class	I	I	I	I	I	I
Core U/I	180/78	210/63	210/73	210/88	210/103	240/83
Recommended use when used in accordance with DIN VDE 0100-710	25 A gL/gG	35 A gL/gG	50 A gL/gG	50 A gL/gG	63 A gL/gG	80 A gL/gG
Induction	1.0 T	1.0 T	1.0 T	1.05 T	1.1 T	1.09 T
$R_{primary}$	$< 0.30 \Omega$	$< 0.23 \Omega$	$< 0.16 \Omega$	$< 0.10 \Omega$	$< 0.065 \Omega$	$< 0.071 \Omega$
$R_{secondary}$	$< 0.25 \Omega$	$< 0.17 \Omega$	$< 0.11 \Omega$	$< 0.08 \Omega$	$< 0.053 \Omega$	$< 0.045 \Omega$
Efficiency	95 %	95 %	96 %	96 %	96 %	96 %
Documentation number: D00151						
Loss						
Fe loss (iron loss)	≤ 45 W	≤ 40 W	≤ 48 W	≤ 56 W	≤ 70 W	≤ 76 W
Cu loss (copper loss)	≤ 145 W	≤ 165 W	≤ 159 W	≤ 178 W	≤ 205 W	≤ 310 W
Heat dissipation loss	≤ 190 W	≤ 205 W	≤ 207 W	≤ 234 W	≤ 275 W	≤ 386 W



Bender GmbH & Co. KG

Londorfer Straße 65
35305 Grünberg
Germany

Tel.: +49 6401 807-0
info@bender.de
www.bender.de



© Bender GmbH & Co. KG, Germany
Subject to change!
The specified standards take into account the
edition valid until 10.2025 unless otherwise
indicated.