

ISOSCAN® EDS440 and EDS441

Insulation fault locator to locate insulation faults in ungrounded DC, AC and three-phase power supplies



ISOSCAN® EDS440 and EDS441

Insulation fault locator to locate insulation faults in ungrounded DC, AC and three-phase power supplies



System properties

- Universal system design
- Modular design, therefore easily adjustable to the given circumstances
- Measuring current transformers available in various sizes and versions
- CT connection monitoring
- Twelve measuring channels for series W..., WR... measuring current transformers
- Optional extension by twelve relay channels
- Fault memory behaviour selectable
- Up to 50 EDS insulation fault locators in the system, 600 measuring channels
- Response sensitivity:
 - EDS440...: 2...10 mA
 - EDS441...: 0.2...1 mA
- AC residual current measurement with configurable response value
- Two alarm relays with one n/o contact each
- n/o or n/c operation selectable
- External test/reset button
- Central display of faulty outgoing circuits
- Serial interface RS-485, BS bus address range 2...79
- Connection to higher-level control and visualisation systems possible.

Intended use

The insulation fault locators ISOSCAN® EDS440 and EDS441 are used to locate insulation faults in unearthed DC, AC and three-phase power supply systems (IT systems). Depending on the locating current injector, AC and three-phase systems can be monitored within the range from AC 42 to 1000 V; DC systems, within the range from DC 24 to 1500 V.

An AC residual current can be indicated in these ranges:

- EDS440: 42...1000 Hz, 0.1...20 A
- EDS441: 42...60 Hz, 0.1...2 A

An EDS system (insulation fault location system) consists of an EDS44x insulation fault locator and a locating current injector. EDS44... insulation fault locators detect locating current signals generated by the locating current injector via measuring current transformers and evaluate them accordingly.

Intended use also implies

- the observation of all information in the operating manual and
- compliance with test intervals.

In order to meet the requirements of the applicable standards, customised parameter settings must be made on the equipment in order to adapt it to local equipment and operating conditions. Please heed the limits of the range of application indicated in the technical data.

Do not make any unauthorised changes to the device. Only use spare parts and optional accessories sold or recommended by the manufacturer.

The messages of the device must be perceptible even if it is installed in a control cabinet.

The device is not designed for use in residential areas and may not provide sufficient protection for radio reception there.

Any other use than that described in this manual is regarded as improper.

Areas of application

- Insulation fault location in AC, 3(N)AC and DC IT systems
- Main circuits and control circuits in industrial plants and ships
- Diode-decoupled DC IT systems in power plants
- Systems for medical locations

Standards

The standard for unearthed power supplies (IT systems)

DIN VDE 0100-410 (VDE 0100-410):2018-10 (IEC 60364-4-41:2005, modified + A1:2017, modified)

requires that the first insulation fault is to be eliminated with the shortest practicable delay. EDS systems enable fast localisation of this insulation fault.

Operating principle of the EDS system

When an insulation monitoring device detects an insulation fault, it starts the insulation fault location.

In the event of a first insulation fault, an undefined residual current flows in IT systems, which is primarily defined by the system leakage capacitances and the value of the insulation fault. The basic idea of insulation fault location is therefore to generate a defined locating current I_L that flows through the insulation fault. The locating current is driven by the system voltage and can be located in the faulty outgoing circuit using the measuring current transformer.

The locating current is generated by the locating current injector. It is limited in amplitude and time. The amplitude depends on the size of the existing insulation fault and the system voltage. It is limited depending on the settings.

The locating current flows from the locating current injector via the live lines to the insulation fault location taking the shortest route. From there, it flows through the insulation fault and the earth conductor back to the locating current injector. This locating current pulse is detected by the measuring current transformers on the insulation fault path and signalled by the connected insulation fault locator.

System variants

The devices ISOSCAN® EDS440 and EDS441 differ depending on their response sensitivity. EDS440 is suitable for main circuits. EDS441 can be used in control circuits and in circuits in medical locations.

	-L	-S	-LAB-4	-LAF-4
EDS440	Channel LED BS bus $I_{\Delta L} = 2 \dots 10 \text{ mA}$ Main circuits Digital inputs and outputs	No channel LED BB bus $I_{\Delta L} = 2 \dots 10 \text{ mA}$ Main circuits No internal voltage supply		Channel LED BS bus $I_{\Delta L} = 10 \text{ mA}^{2)}$ Main circuits Digital inputs and outputs
EDS441	Channel LED BS-Bus $I_{\Delta L} = 0.2 \dots 1 \text{ mA}$ Control circuits Digital inputs and outputs	No channel LED BB bus $I_{\Delta L} = 0.2 \dots 1 \text{ mA}$ Control circuits No internal voltage supply	Channel LED BS-Bus $I_{\Delta L} = 0.2 \dots 1 \text{ mA}^{1)}$ Control circuits W...AB current transformers Digital inputs and outputs	

- 1) High response sensitivity with large system leakage capacitances
- 2) In combination with CTAF...SET series measuring current transformers

Operating and display elements EDS44...-L

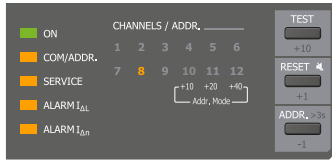

Display elements EDS44...-S



Status LEDs

ON	Flashes: Starting process; hourly transformer connection test Lights up: operational
COM/ADDR.	Flashes quickly: device communicates via RS-485 interface Flashes: insulation fault location (LED indicate the pulse of the locating current injector: pulse = on; pause = off. In LAB procedure, the pulse can last one minute.)
SERVICE	Lights up: device error; connection fault of the measuring current transformers; error message e.g. due to low-frequency residual currents, external magnetic fields, etc.
ALARM I_{ΔL}	Lights up: main alarm, insulation fault on one of the measuring channels (EDS function)
ALARM I_{Δn}	Lights up: response value for residual currents is exceeded.

Status LED

ON	Flashes: Starting process; hourly transformer connection test Lights up: operational
-----------	---

Channel LEDs 1 to 12

CHANNELS / ADDR.	Lights up: insulation fault on the respective measuring channel or residual current alarm Flashes slowly (1 Hz): connection fault of the measuring current transformer Flashes quickly (2 Hz): interference during insulation fault location
Addr. Mode	Indication of the present tens counter by means of the channel LEDs 10, 11 and 12

Operating buttons

TEST	Starts self test.
+10	In address assignment mode: increase address in steps of ten.
RESET	Resets the fault memory. Only possible if the fault memory is activated and a fault is no longer detected.
+1	In address assignment mode: increase address in steps of one.
ADDR.	Long press (>3 s): activates the address assignment mode.
-1	In address assignment mode: decrease address in steps of one.

Connection to the voltage supply

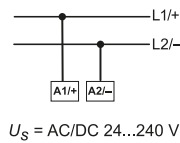
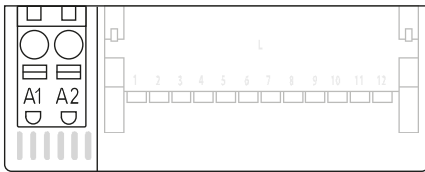

i Voltage supply back-up fuse

If the device is supplied via an external power supply unit, the back-up fuse $F_{back-up}$ at connection "A1/+ A2/-" must be selected in such a way that the feeding power supply unit is able to trip the DC-compatible back-up fuse.

Example:

A back-up fuse of 650 mA/T is recommended when using a 24 V power supply unit (min. 1 A).

Connection of the X1 interface (I1, I2, A, B, M+, ...)

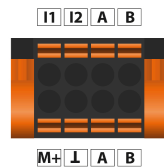
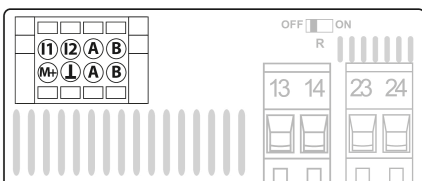

I1	Input 1	M+	dig. current output
I2	Input 2	\perp	Ground
A	RS-485 A (input)	A	RS-485 A (output)
B	RS-485 B (input)	B	RS-485 B (output)

i The EDS44...-L is connected via the X1 plug.
The EDS44...-S does not feature an X1 interface and can only be connected via the BB bus.

Connection of the relays

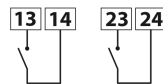
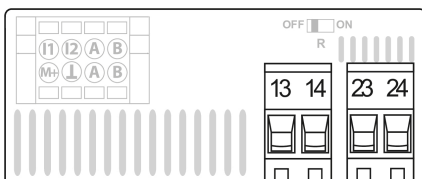

Alarm relay 1	13 14	n/o contact
Alarm relay 2	23 24	n/o contact

BS bus termination

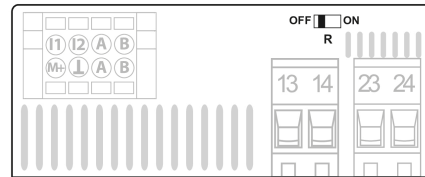

OFF	All devices between the first and the last device in the bus
ON	First and last device in a bus

Activating a terminating resistor to define the first and the last device in the bus system.

Connection of the X2 interface (k1-12/I1-12)

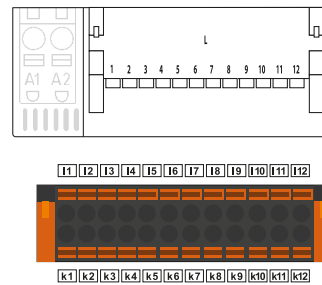

I1	Measuring current transformer 1	k1
I2	Measuring current transformer 2	k2
I3	Measuring current transformer 3	k3
I4	Measuring current transformer 4	k4
...
I12	Measuring current transformer 12	k12

i Cable lengths of the measuring current transformers
Install the measuring current transformers according to the instructions in the respective data sheet of the measuring current transformer. When connecting, observe the maximum cable lengths.

Connection of CTAC... series measuring current transformers

For insulation fault location, the measuring current transformers of the CTAC... series are used.

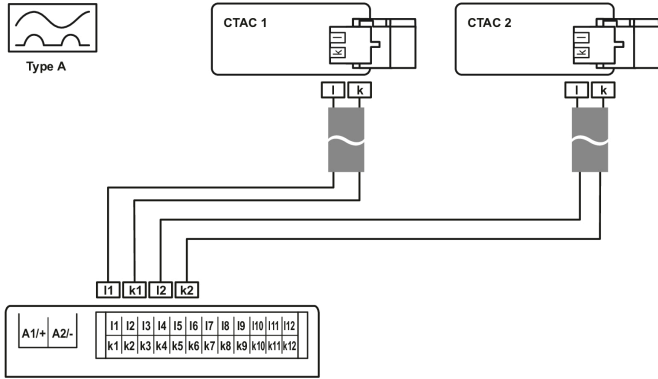

i **CTAC... series measuring current transformers**
 Terminals 1 and 2 as well as terminals 3 and 4 of the measuring current transformer are bridged internally. The connections k and I must not be interchanged on the EDS44....

i **Live conductors and measuring current transformers**
 Ensure that all live conductors are routed through the measuring current transformer. Do not route any existing PE conductors or shields of shielded cables through the measuring current transformer! Standard measuring current transformers are not suitable for the EDS44... system and must not be used. An accurate measurement result can only be obtained when these instructions are observed.

For further information regarding measuring current transformers, refer to the respective data sheets.

Connection of measuring current transformer CTBC... to EDS441-LAB-4

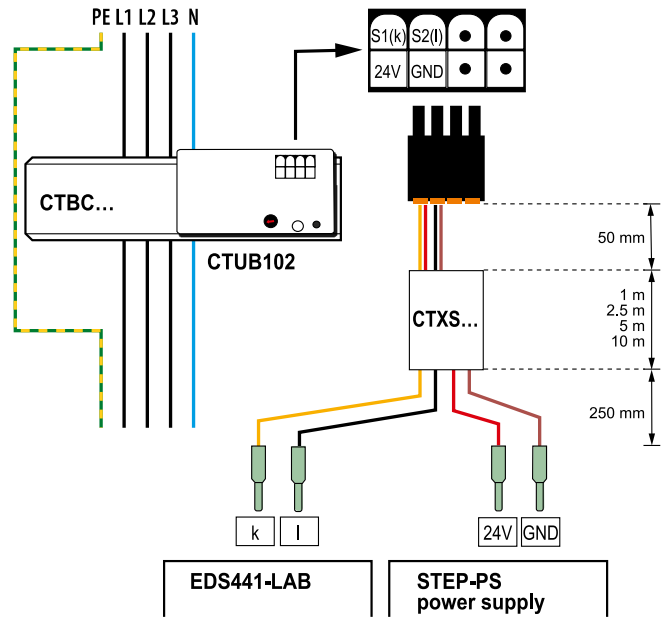

i **Locating current**
 The EDS441-LAB-4 operates exclusively with a locating current of max. 25 mA. Therefore, selecting the current range >500 mA on the current transformer is not suitable for measuring locating currents <25 mA.

Connection of CTAF...SET series measuring current transformers to EDS440-LAF-4

For insulation fault location, the measuring current transformers of the CTAF...SET series are used.

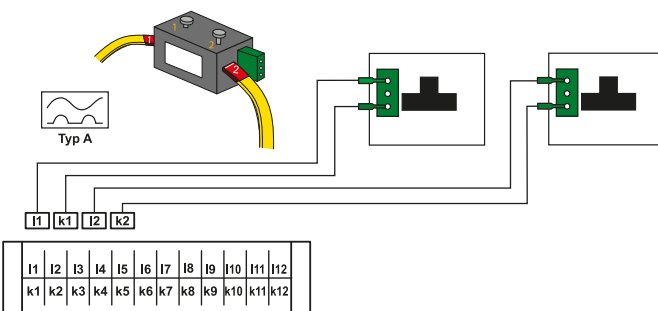

i **Locating current**
 The EDS440-LAF-4 operates exclusively with a locating current >10 mA.

Connection to a 3(N)AC system

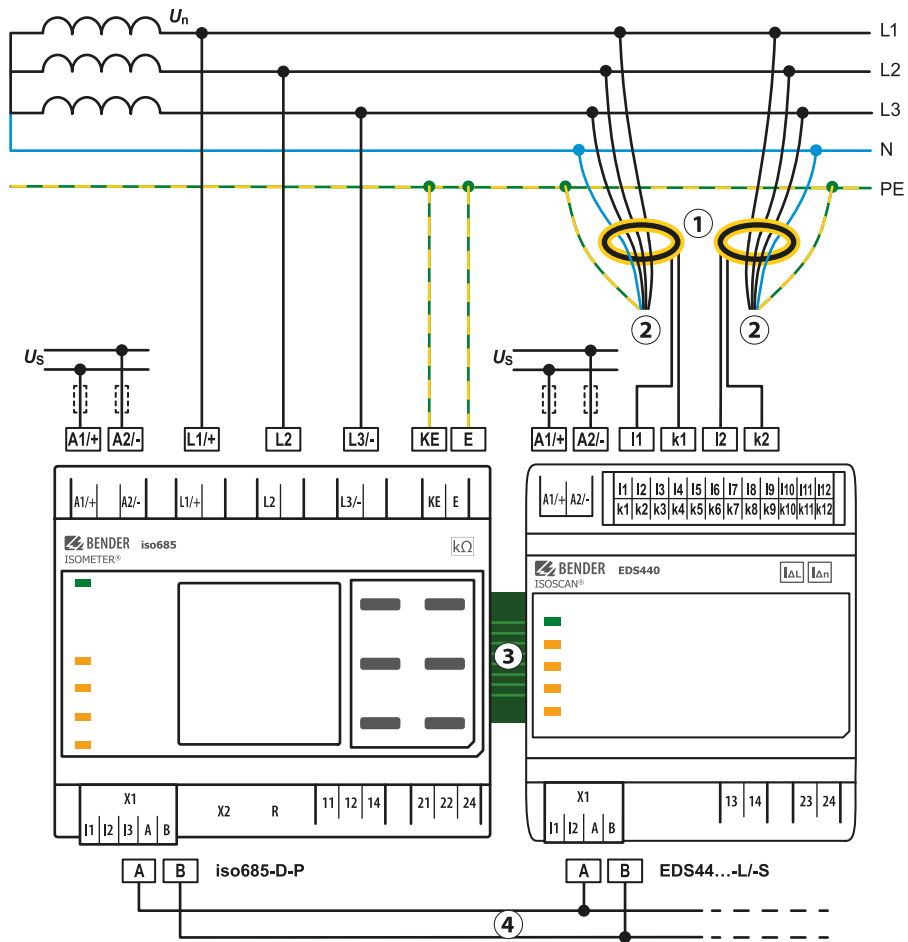

- 1 Measuring current transformers
- 2 to the loads
- 3 BB bus for communication to and supply of EDS44...-S
- 4 BS bus for communication from iso685(W)-...-P to EDS44...-L
- U_s Connection of the supply voltage only to EDS44...-L

Connection to a DC system

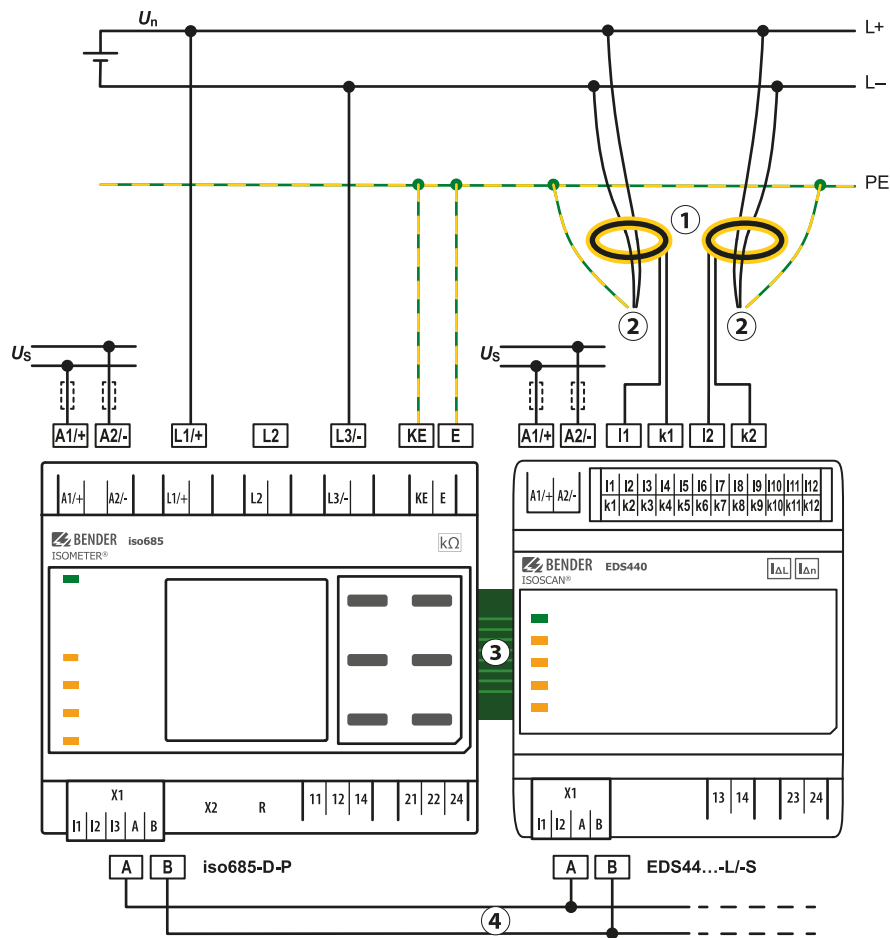

- 1 Measuring current transformers
 - 2 to the loads
 - 3 BB bus for communication to and supply of EDS44...-S
 - 4 BS bus for communication from iso685(W)-...-P to EDS44...-L
- U_s Connection of the supply voltage only to EDS44...-L

Connection to an AC system

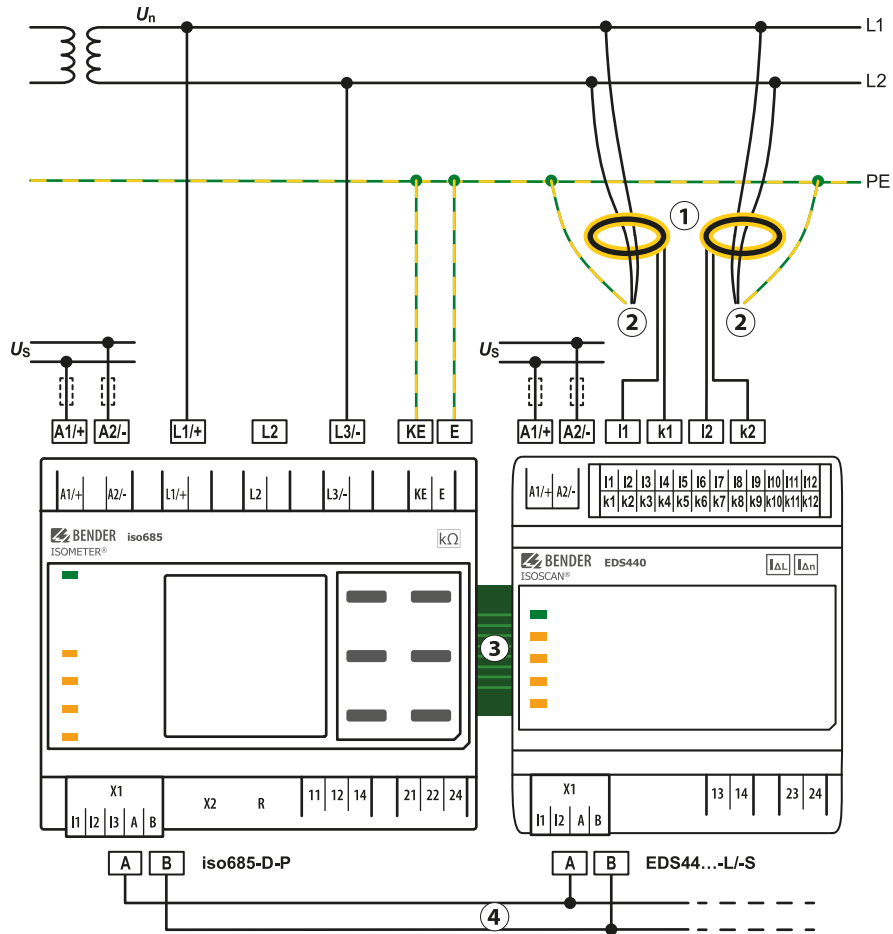

- 1 Measuring current transformers
- 2 to the loads
- 3 BB bus for communication to and supply of EDS44...-S
- 4 BS bus for communication from iso685(W)-...-P to EDS44...-L
- U_s Connection of the supply voltage only to EDS44...-L

Connection example: ISOMETER® iso685-D-P, EDS440-S, IOM441-S and EDS440-L

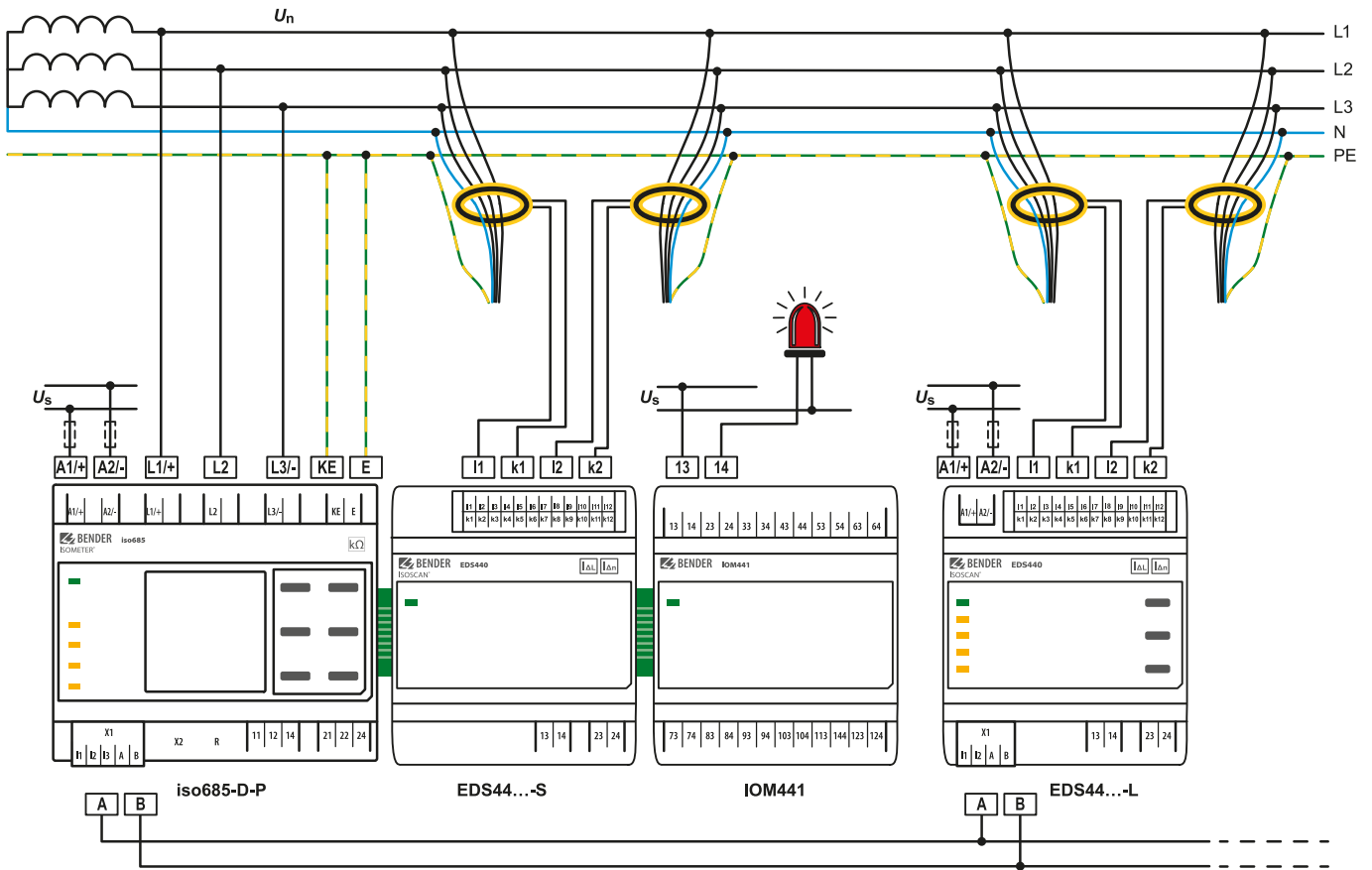

i Communication between iso685-...-P and EDS44-...-L runs exclusively via BS bus (RS-485).

Technical data ISOSCAN® EDS440 and EDS441
Insulation coordination acc. to IEC 60664-1/IEC 60664-3
Definitions

Supply circuit (IC1)	A1, A2
Output circuit 1 (IC2)	13, 14
Output circuit 2 (IC3)	23, 24
Control circuit (IC4)	(A1, A2), (13, 14) - (23, 24) - (X1, X3)
Rated voltage	1000 V
Overvoltage category	III
Range of use	≤ 2000 m AMSL

Rated impulse voltage

IC1/(IC2-4)	4 kV
IC2/(IC3-4)	4 kV
IC3/(IC4)	4 kV

Rated insulation voltage

IC1/(IC2-4)	AC 250 V
IC2/(IC3-4)	250 V
IC3/IC4	250 V
Pollution degree outside ($U_n < 690$ V)	3
Pollution degree outside ($U_n > 690$ V < 1000 V)	2

Protective separation (reinforced insulation) between

IC1/(IC2-4)	Overvoltage category III, 1000 V
IC2/(IC3-4)	Overvoltage category III, 300 V
IC3/IC4	Overvoltage category III, 300 V

Voltage tests (routine test) acc. to IEC 61010-1

IC2/(IC3-4)	AC 2.2 kV
IC3/IC4	AC 2.2 kV

Supply voltage

Supply voltage range U_s EDS44...-L (...-LAB, ...-LAF)	AC/DC 24...240 V
Supply voltage range U_s EDS44...-S	DC 24 V
Tolerance of U_s	-20...+15%
Frequency range of U_s	DC, 50...400 Hz ^{1) 2)} Tolerance: -5...+15 %
Power consumption, typically 50 Hz (400 Hz) EDS44...-L	≤ 4 W / 7 VA (≤ 4 W, 28 VA)
Power consumption, typically (DC via BB bus) EDS44...-S	≤ 1 W

1) At a frequency > 200 Hz, the connection of X1 and k1-12/11-12 must be insulated. Only permanently installed devices which at least have overvoltage category CAT2 (300 V) may be connected.

2) Only 50/60 Hz are permitted for UL applications.

Response values

	EDS440	EDS441
Response value for insulation fault location ($I_{\Delta L}$)	2...10 mA	0.2...1 mA
Relative uncertainty ($I_{\Delta L}$) ³⁾	±30 %, min. ±2 mA	±30 %, min. ±0.2 mA
Response value for residual current measurement ($I_{\Delta n}$)	0.1...10 A	0.1...1 A
Relative uncertainty ($I_{\Delta n}$) 42...60 Hz	±5 %	±5 %
Relative uncertainty ($I_{\Delta n}$) 61...1000 Hz	-20...0 %	-20...0 %
Hysteresis	20 %	20 %

3) Residual current effect of > 100 mA results in a greater relative uncertainty.

Time response

Scanning time for all channels for insulation fault location ($I_{\Delta L}$)	profile-dependent, min. 6 s
Response time for residual current measurement ($I_{\Delta n}$)	≤ 400 ms
Response time for measuring current transformer monitoring	max. 18 min

Measuring circuit

Nominal system voltage U_n EDS440	refer to locating current injector (e.g. ISOMETER® iso685-D-P)
Nominal system voltage U_n EDS441	AC 230 V ±15 % DC 220 V ±40 %
External measuring current transformers for EDS440	W..., WR...
External measuring current transformers for EDS441	W.../8000
External measuring current transformers for EDS441-LAB	CTUB102
External measuring current transformers for EDS440-LAF	CTAF...
Load EDS440	47 Ω
Load EDS441, EDS440-LAF	1.5 kΩ
Rated insulation voltage, measuring current transformers	800 V

Connection of EDS measuring current transformers

Single wire ≥0.75 mm ²	0...1 m
Single wire, twisted ≥0.75 mm ²	1...10 m
Shielded cable ≥0.5 mm ²	10...40 m
Recommended cable (shielded, shield connected to earth on one side)	J-Y(St)Y min. 2 × 0.8

Measuring ranges, insulation fault location $I_{\Delta L}$

Rated frequency range	DC, 16.7...1000 Hz
Measuring range, insulation fault location ($I_{\Delta L}$) EDS440	1.5...50 mA
Measuring range, insulation fault location ($I_{\Delta L}$) EDS441	0.15...5 mA
Maximum permissible residual current	see Diagrams in the manual

Measuring range, residual current measurement $I_{\Delta n}$

Measuring range, residual current measurement ($I_{\Delta n}$) EDS440	0.1...20 A
Rated frequency range EDS440-...	50...1000 Hz
Measuring range, residual current measurement ($I_{\Delta n}$) EDS441	0.1...2 A
Rated frequency range EDS441-...	50...60 Hz

LEDs

ON (operation LED)	green
COM	yellow
SERVICE	yellow
ALARM $I_{\Delta L}$	yellow
ALARM $I_{\Delta n}$	yellow
1...12 channel indication	yellow

Digital inputs

Number	2
Operating mode, adjustable	active high, active low
Function	none, test, reset
Voltage level	low DC -5...5 V, high DC 11...32 V

Digital current output

Number	1
Function	none, alarm $I_{\Delta L}$, alarm $I_{\Delta n}$, device error, current transformer connection fault, common alarm, BS bus malfunction
Current	0 mA DC inactive, 20 mA DC active
Tolerance	±10 %
Load resistance	$R \leq 500 \Omega / P_R \geq 0.25 \text{ W}$

Buzzer

Number	1
Function	none, alarm $I_{\Delta L}$, alarm $I_{\Delta n}$, device error, CT connection fault, insulation fault location active, common alarm

Interfaces

Interface/protocol	RS-485 BS-Bus Modbus RTU
Data rate BS bus	9.6 kBd
Data rate Modbus RTU	9.6 19.2 38.4 57.6 115.2 kBd
Cable length	≤ 1200 m
Cable: twisted pair, shield connected to earth on one side	recommended: min. CAT6/7
Connection	X1.A, X1.B
Terminating resistor	120 Ω , built-in, switchable
Device address, BS bus	0, 2...79 (optional 0, 2...159)

Switching elements

Switching elements	2 n/o contacts
Operating mode	n/c, n/o
Function of contact 13, 14	none, alarm $I_{\Delta L}$, alarm $I_{\Delta n}$, device error, CT connection fault, common alarm, BS bus malfunction
Function of contact 23, 24	none, alarm $I_{\Delta L}$, alarm $I_{\Delta n}$, device error, CT connection fault, common alarm, BS bus malfunction
Electrical endurance under rated operating conditions	30,000 h
Rated operational voltage	AC 250 V
Rated operational current	7 A
Rated insulation voltage	4 kV

Contact data acc. to IEC 60947-5-1

Utilization category	AC-13 / AC-14 / DC-12 / DC-12 / DC-12 / DC-12
Rated operational voltage	230 V / 230 V / 24 V / 48 V / 110 V / 220 V
Rated operational current	5 A / 3 A / 1 A / 1 A / 0.2 A / 0.1 A
Max. switching capacity	300 W / 2770 VA
Max. switching voltage	DC 30 V / AC 277 V
Minimum contact rating	11 mA at AC/DC ≥ 10 V

Environment/EMC

EMC	IEC 61326-2-4
-----	---------------

Ambient temperatures

Operating temperature	-25...+55 °C
Transport	-40...+85 °C
Storage	-25...+70 °C

Climatic conditions acc. to IEC 60721

Stationary use (IEC 60721-3-3)	3K22
Transport (IEC 60721-3-2)	2K11
Long-term storage (IEC 60721-3-1)	1K22

Mechanical conditions acc. to IEC 60721

Stationary use (IEC 60721-3-3)	3M11
Transport (IEC 60721-3-2)	2M4
Long-term storage (IEC 60721-3-1)	1M12

Connection

Screw-type terminals

Tightening torque	0.5...0.6 Nm (5...7 lb-in)
Conductor sizes	AWG 24...12
Stripping length	7 mm
Rigid/flexible	0.2...2.5 mm ²
Flexible with ferrule, with/without plastic sleeve	0.25...2.5 mm ²
Multiple conductor, rigid	0.2...1 mm ²
Multiple conductor, flexible	0.2...1.5 mm ²
Multiple conductor, flexible with ferrule without plastic sleeve	0.25...1 mm ²
Multiple conductor, flexible with TWIN ferrule with plastic sleeve	0.5...1.5 mm ²

Push-wire terminals

Conductor sizes	AWG 24...12
Stripping length	10 mm
Rigid/flexible	0.2...2.5 mm ²
Flexible with ferrule, with/without plastic sleeve	0.25...2.5 mm ²
Multiple conductor, flexible with TWIN ferrule with plastic sleeve	0.5...1.5 mm ²

Push-wire terminals X1, X2

Conductor sizes	AWG 24...16
Stripping length	10 mm
Rigid/flexible	0.2...1.5 mm ²
Flexible with ferrule without plastic sleeve	0.25...1.5 mm ²
Flexible with ferrule with plastic sleeve	0.25...0.75 mm ²

Other

Operating mode	continuous operation
Mounting	
ambient temperature > 55 °C	vertical
ambient temperature < 55 °C	any alignment
Degree of protection, internal components	IP40
Degree of protection, terminals	IP20
DIN rail mounting	IEC 60715
Screw fixing	2 × M4 with mounting clip
Enclosure material	polycarbonate
Flammability class	UL 94 V-0
Dimensions in mm (W × H × D)	72 × 93 × 63
Weight	
EDS44...-S	approx. 122 g
EDS44...-L, ...-LAB, ...-LAF	approx. 242 g

“W” option data deviating from the standard version

Devices with the suffix “W” feature increased shock and vibration resistance. The electronics is covered with a special varnish to provide increased protection against mechanical stress and moisture.

Ambient temperatures

Operating temperature	-40...+70 °C
Transport	-40...+85 °C
Long-term storage	-25...+70 °C

Climatic conditions acc. to IEC 60721

Stationary use (IEC 60721-3-3)	3K23
--------------------------------	------

Mechanical conditions acc. to IEC 60721

Stationary use (IEC 60721-3-3)	3M12
--------------------------------	------

Standards and certifications

Observe the applicable national and international standards.

The EDS44... series meets the device standards:

- DIN VDE 0100-410 (VDE 0100-410)
- DIN EN 61557-9 (VDE 0413-9)
- IEC 61557-9
- DIN EN 50155 (VDE 0115-200)
- DIN EN 45545-2:2016

Subject to change! The specified standards take into account the edition valid until 08/21 unless otherwise indicated.

The operating manuals for the individual system components provide you with information about the standards that apply to that particular device.



EU declaration of conformity

Hereby, Bender GmbH & Co. KG declares that the device covered by the Radio Directive complies with Directive 2014/53/EU. The full text of the EU Declaration of Conformity is available at the following Internet address:

 www.bender.de/fileadmin/content/Products/CE/CEKO_EDS44x.pdf

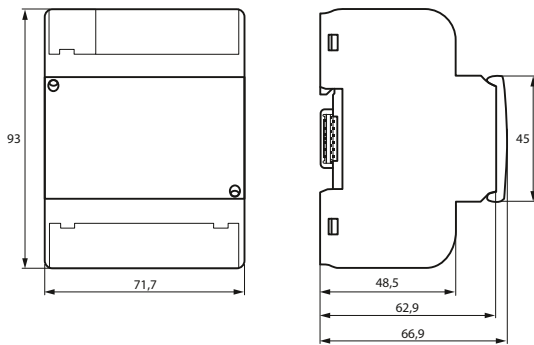
External dimensions of EDS44... and IOM441-S

External dimensions in mm

Ordering data
Insulation fault locators

Type	Supply voltage U_s (absolute values)	Response value	Art. no.
EDS440-S-1	DC 24 V	2...10 mA	B91080201
EDS440W-S-1	DC 24 V	2...10 mA	B91080201W
EDS440-L-4	AC/DC 24...240 V	2...10 mA	B91080202
EDS440W-L-4	AC/DC 24...240 V	2...10 mA	B91080202W
EDS441-S-1	DC 24 V	0.2...1 mA	B91080204
EDS441W-S-1	DC 24 V	0.2...1 mA	B91080204W
EDS441-L-4	AC/DC 24...240 V	0.2...1 mA	B91080205
EDS441W-L-4	AC/DC 24...240 V	0.2...1 mA	B91080205W
EDS441-LAB-4	AC/DC 24...240 V	0.2...1 mA	B91080207
EDS441W-LAB-4	AC/DC 24...240 V	0.2...1 mA	B91080207W
EDS440-LAF-4	AC/DC 24...240 V	10 mA	B91080209

Accessories

Description	Art. no.
EDS440/441 mechanical accessories comprising: terminal cover and 2 mounting clips (scope of delivery)	B91080903
EDS440/441 plug kit, screw terminals (scope of delivery)	B91080901
EDS440/441 plug kit, push-wire terminals	B91080902
BB bus 4TE plug connection (scope of delivery EDS44x(W)-S-1)	B98110002

Type	Supply voltage U_s	Art. no.
DI-1 PSM (RS-485 repeater)	AC/DC 24 V ±20 %	B95012044
DI-2 USB (interface converter RS-485/USB) with USB cable	Supplied by USB interface	B95012045
IOM441-S (input/output module)	12-way relay module	B95012057
AN420 (PSU for W...AB current transformers)	AC, 100...250 V 50/60 Hz, DC ±12 V	B74053100
	DC, 100...250 V, DC ±12 V	B94053100
AN471 (PSU for DI-1 or DI-2)	AC 230 V 50/60 Hz AC, DC 20 V	B924189
Snap-on mounting W20.../35...		B98080501
Snap-on mounting W60...		B98080502

Measuring current transformers

For further information regarding the measuring current transformers, refer to the data sheets.

Measuring current transformers for EDS440
Recommended Bender measuring current transformers

Type	Internal diameter in mm	Design type	Art. no.
CTAC20	ø20	circular	B98110005
CTAC35	ø35	circular	B98110007
CTAC60	ø60	circular	B98110017
CTAC120	ø120	circular	B98110019
CTAC210	ø210	circular	B98110020

Alternative measuring current transformers from the Bender program

Type	Dimensions / internal diameter in mm	Design type	Art. no.
CTAS50	ø50	split-core	B98110009
CTAS80	ø80	split-core	B98110010
CTAS120	ø120	split-core	B98110011
W10/600	ø10	circular	B911761
W0-S20	ø20	circular	B911787
W1-S35	ø35	circular	B911731
W2-S70	ø70	circular	B911732
W3-S105	ø105	circular	B911733
W4-S140	ø140	circular	B911734
W5-S210	ø210	circular	B911735
WR70x175S	70 × 175	rectangular	B911738
WR115x305S	115 × 305	rectangular	B911739
WR150x350S	150 × 350	rectangular	B911740
WR200x500S	200 × 500	rectangular	B911763
WR70x175SP	70 × 175	rectangular	B911790
WR115x305SP	115 × 305	rectangular	B911791
WR150x350SP	150 × 350	rectangular	B911792
WR200x500SP	200 × 500	rectangular	B911793

Measuring current transformers for EDS441

Recommended Bender measuring current transformers

Type	Internal diameter in mm	Design type	Art. no.
CTAC20/01	ø20	circular	B98110006
CTAC35/01	ø35	circular	B98110008

Alternative measuring current transformers from the Bender program

Type	Dimensions / internal diameter in mm	Design type	Art. no.
CTAS50/01	ø50	split-core	B98110012
CTAS80/01	ø80	split-core	B98110013
CTAS120/01	ø120	split-core	B98110014
W10/8000	ø10	circular	B911759
W10/8000-6	ø10	circular, 6-fold	B911900

Measuring current transformers for EDS441-LAB

Bender measuring current transformers

Type	Internal diameter in mm	Design type	Art. no.
CTUB102-CTBC20P	ø20	circular	B78120021
CTUB102-CTBC35P	ø35	circular	B78120023
CTUB102-CTBC60P	ø60	circular	B78120025

Measuring current transformers for EDS440-LAF

Bender measuring current transformers

Typ	Dimensions in mm	Design type	Art. no.
CTAF500SET	500	flexible	B98110022
CTAF1000SET	1000	flexible	B98110023



Bender GmbH & Co. KG

Londorfer Straße 65
35305 Grünberg
Germany

Tel.: +49 6401 807-0
info@bender.de
www.bender.de



© Bender GmbH & Co. KG, Germany
Subject to change!
The specified standards take into account the edition valid until 02.2026 unless otherwise indicated.