

EDS3090/-91/-92/-96

Portable equipment for insulation fault location
for energised and deenergised AC and DC systems



Image similar



Device features

- Portable insulation fault location systems for IT systems AC 0...790 V, 42...460 Hz/DC 0...960 V or de-energised systems
- Residual current measurement in TN/TT systems
- Use in main and control circuits, photovoltaic systems
- Measuring clamps 20/52 mm (115 mm optional)
- Robust aluminium case, convenient to carry
- Locating current injectors PGH18... with variable locating current 1...25 mA
- Integrated locating voltage for de-energised systems (PGH186)

Insulation fault EDS195P(M)

- Backlit LC display, 3 x 16 characters
- Measuring clamps 20/52 mm included in the scope of delivery
- Accumulator (delivered with a power supply unit)
- Response value insulation fault location 2...10 mA for main circuits
- Response value insulation fault location 0.2...1 mA for control circuits
- Response value residual current measurement 10 mA...10 A
- Selectable operating mode insulation fault location/residual current measurement

Intended use

The portable insulation fault location system EDS309... is used to locate insulation faults in IT systems. All variants are suitable for the measurement of residual currents in TN and TT systems. The EDS3096PG is particularly suitable for insulation fault location in electrically isolated systems.

Please observe the limits on the area of application stated in the technical specifications, as well as the measuring categories for the measuring clamps used. If, in the specific case, measuring current transformers other than the measuring clamps supplied are used with the EDS195P(M), adequate nominal insulation voltage must be ensured for the connection wires and transformer (overvoltage category, see Technical data).

Do not make any unauthorised changes to the device. Only use spare parts and optional accessories sold or recommended by the manufacturer.

Any other use than that described in this manual is regarded as improper.

Function of the system components

The following system components are required for correct operation:

Locating current injector PGH18...

The PGH18... generates a defined locating current. The current depends on the insulation fault and the system voltage.

- The PGH185 or PGH186 limits the locating current to maximum 25 mA or maximum 10 mA depending on the switch setting.
- The PGH183 limits the locating current to maximum 2.5 mA or maximum 1 mA depending on the switch setting.
- The PGH186 applies the locating current in electrically isolated IT systems or in IT systems with a system voltage < 50 V using an integrated voltage source (DC 50 V). In IT systems with a system voltage > 50 V the existing voltage in the system is used to drive the locating current.

Insulation fault locator EDS195P(M)

- Insulation fault location $I_{\Delta L}$ (EDS mode) for use in IT AC or DC systems:
 - Either as a component of the portable equipment for insulation fault location EDS309...
 - Or as an additional insulation fault locator in permanently installed equipment for insulation fault location with IRDH575, iso685-x-P or isoxx1685xP or PGH1... as well as EDS4...
 - EDS195PM - only devices with the suffix "M" have the measuring signal output for connecting an oscilloscope
- Residual current measurement $I_{\Delta n}$ (mode) for usage in TN or TT AC systems.

Measuring clamps

Measuring clamps measure the locating current or the residual current. They have a test lead approx. 2 m long. They are connected to the EDS195P(M) via a BNC connector.

If measuring current transformers are used instead of measuring clamps, you will need the adapter supplied: BNC/4-mm connector. See "[Component list](#)", page 14.

Coupling device AGE185

The coupling device AGE185 expands the nominal voltage range of the equipment for insulation fault location EDS309.... It enables the equipment to be connected to system nominal voltages up to AC 790 V or DC 960 V.

Insulation fault location equipment type list

Residual current measurement is possible in TT and TN systems (earthed systems) using the device variants listed below. The following overview describes which tasks can be done with which models.

Equipment for insulation fault location in main circuits

1. Permissible system voltage in the main circuits:

- Insulation fault location in IT systems up to AC 42...460 Hz, 20...575 V and DC 20...504 V
- Insulation fault location using AGE185 up to AC 42...460 Hz, 500...790 V and DC 400...960 V

EDS3090:

- Can be used in IT systems in which a locating current injector (e.g. PGH471) or an ISOMETER® with integrated locating current injector (e.g. iso685-x-P) is already installed.

EDS3090PG:

- Can be used in IT systems in which no locating current generator and no ISOMETER® with integrated locating current generator is installed.
- Supply voltage for the locating current generator PGH185 supplied: AC 50...60 Hz, 230 V

EDS3090PG-13:

- Can be used in IT systems in which no locating current generator and no ISOMETER® with integrated locating current generator is installed.
- Supply voltage for the locating current generator PGH185-13 supplied: AC 50...60 Hz, 90...132 V

2. Permissible system voltage in the main circuits:

- Insulation fault location in IT systems up to AC 42...460 Hz, 0...575 V and DC 0...504 V
- Insulation fault location using AGE185 up to AC 42...460 Hz, 500...790 V and DC 400...960 V

EDS3096PG:

- Can be used in IT systems in which no locating current generator and no ISOMETER® with integrated locating current generator is installed.
- Supply voltage for the locating current generator PGH186 supplied: AC 50...60 Hz, 230 V
- Insulation fault location, also in IT systems electrically isolated on all poles

EDS3096PG-13:

- Can be used in IT systems in which no locating current generator and no ISOMETER® with integrated locating current generator is installed.
- Supply voltage for the locating current generator PGH186-13 supplied: AC 50...60 Hz, 90...132 V
- Insulation fault location, also in IT systems electrically isolated on all poles

EDS3096PV:

- Applicable in PV systems without a locating current injector installed
- Supply voltage for the delivered locating current injector PGH186: AC 50...60 Hz, 230 V
- Insulation fault location, also in IT systems disconnected on all poles or in de-energised IT systems

Accessories CTAF:

- Set with flexible clamps with band lengths of 500 and 1000 mm
- Application for cables with big dimensions or in systems with narrow space conditions
- Combinable with EDS3090, EDS3092, EDS3096
- The minor response sensitivity towards the clamps PSA3... in chapter "Response sensitivity characteristics of the EDS195PM" in the manual must be considered.

Equipment for insulation fault location in control circuits

Permissible system voltage in the control circuits:

- Insulation fault location in IT systems up to AC 42...460 Hz, 20...265 V and DC 20...308 V

EDS3091:

- Can be used in IT systems in which a locating current injector (e.g. PGH473) or an ISOMETER® with integrated locating current injector (e.g. iso685-x-P) is already installed.

EDS3091PG:

- Can be used in IT systems in which no locating current generator and no ISOMETER® with integrated locating current generator is installed.
- Supply voltage for the locating current generator PGH183 supplied: AC 50...60 Hz, 230 V

EDS3091PG-13:

- Can be used in IT systems in which no locating current generator and no ISOMETER® with integrated locating current generator is installed.
- Supply voltage for the locating current generator PGH183-13 supplied: AC 50...60 Hz, 90...132 V

Equipment for insulation fault location in main circuits and control circuits

EDS3092PG:

- Contains the components and combines the features of the EDS3090PG and EDS3091PG

Application example

Equipment for insulation fault location EDS3096PG in de-energised systems (IT systems)

(Note: can also be used in TN systems with all poles disconnected)

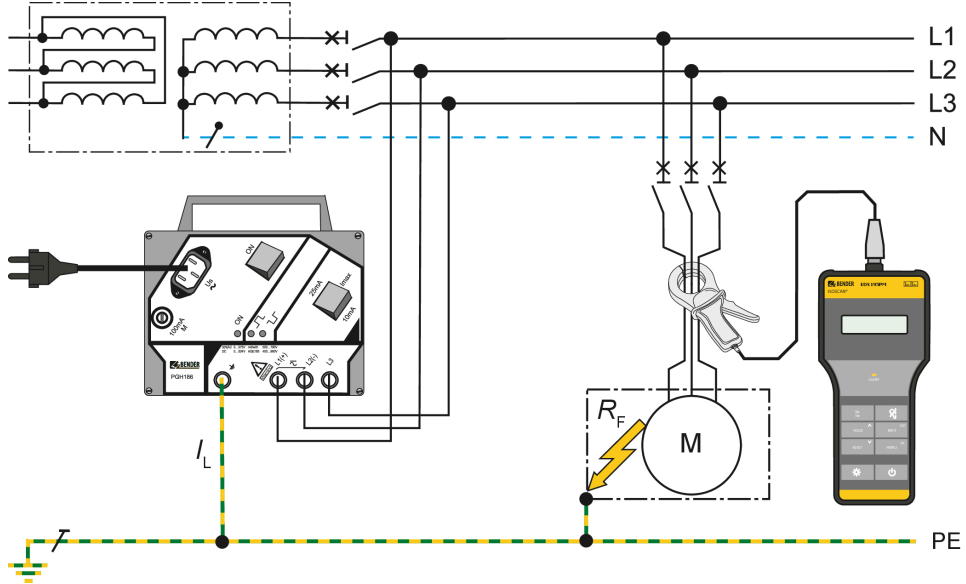

Residual current measurement with EDS309... in earthed systems (TN-S systems)

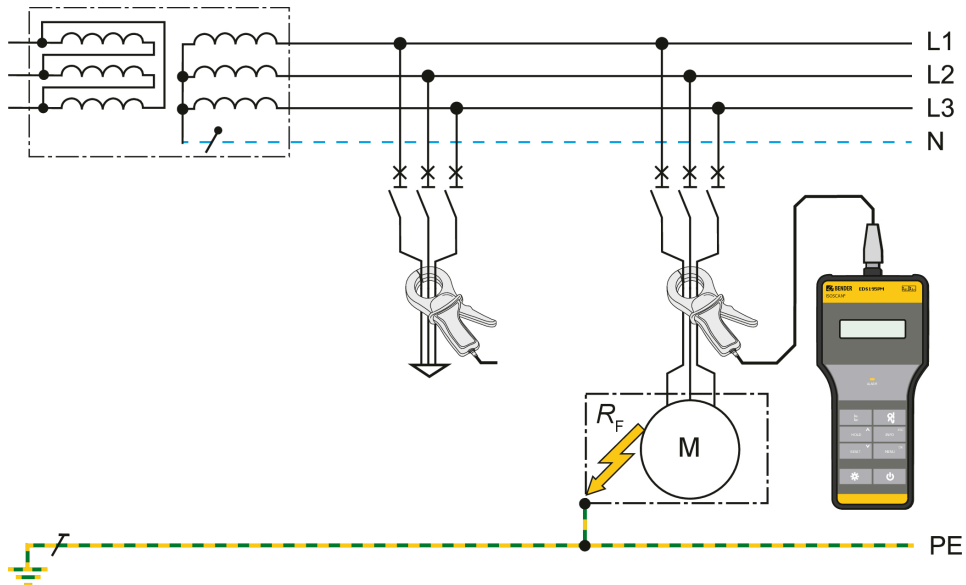

Insulation fault location system EDS3096PV in unearthed photovoltaic systems (IT systems)

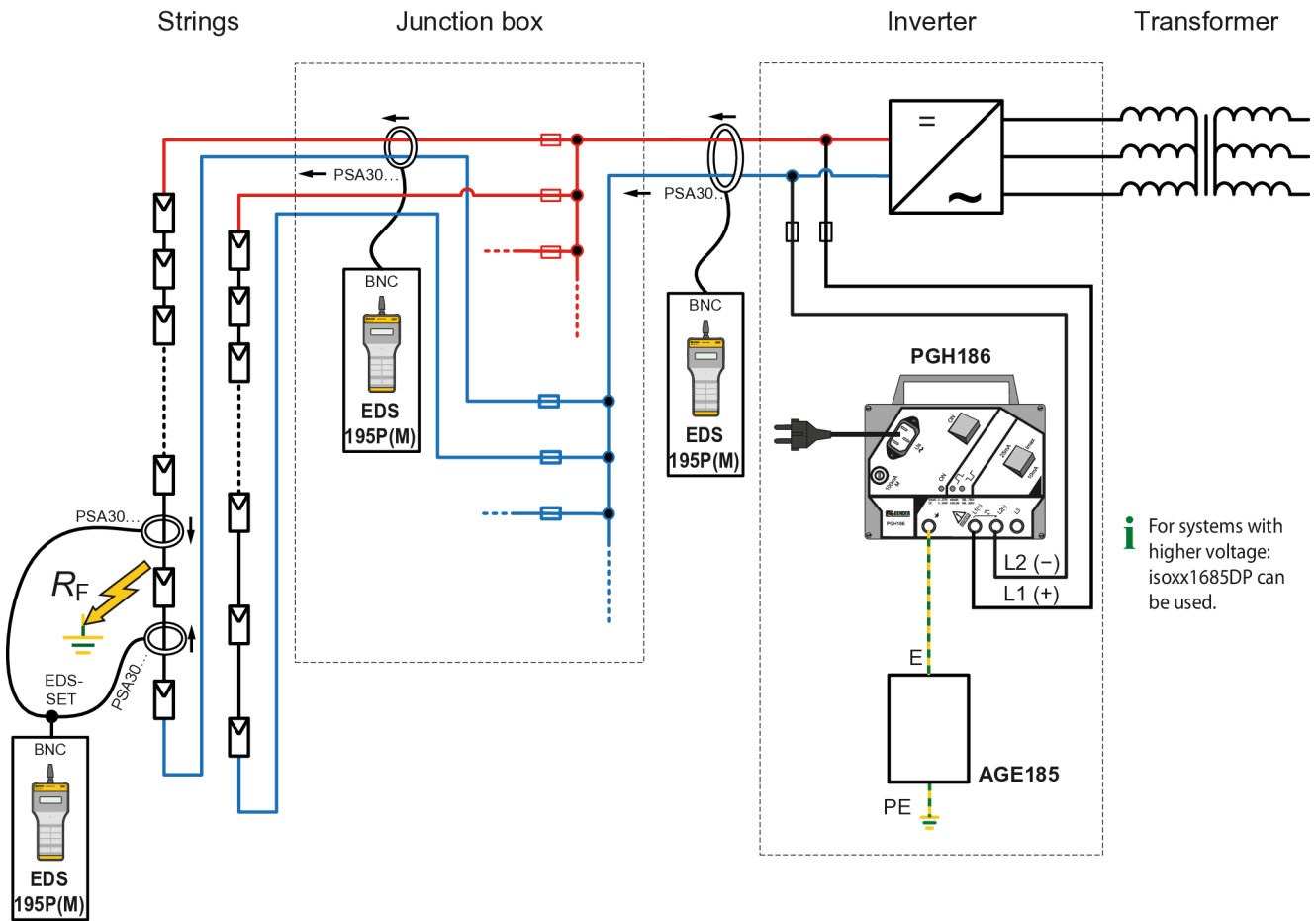

Equipment for insulation fault location EDS3090/3091PG for use in unearthed systems (IT systems) without a permanently installed equipment for insulation fault location

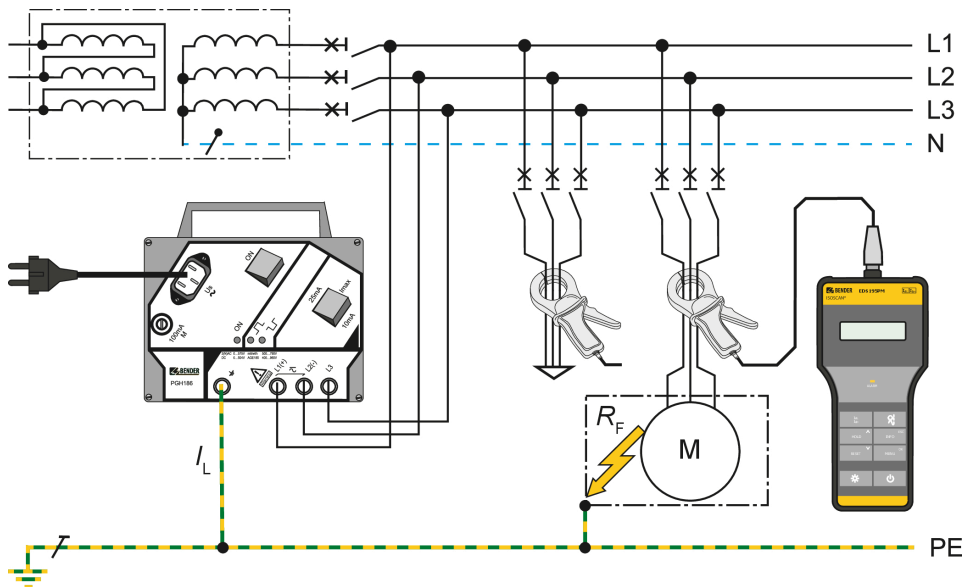

Equipment for insulation fault location EDS3090/3091 in unearthed systems (IT systems) with permanently installed equipment for insulation fault location EDS

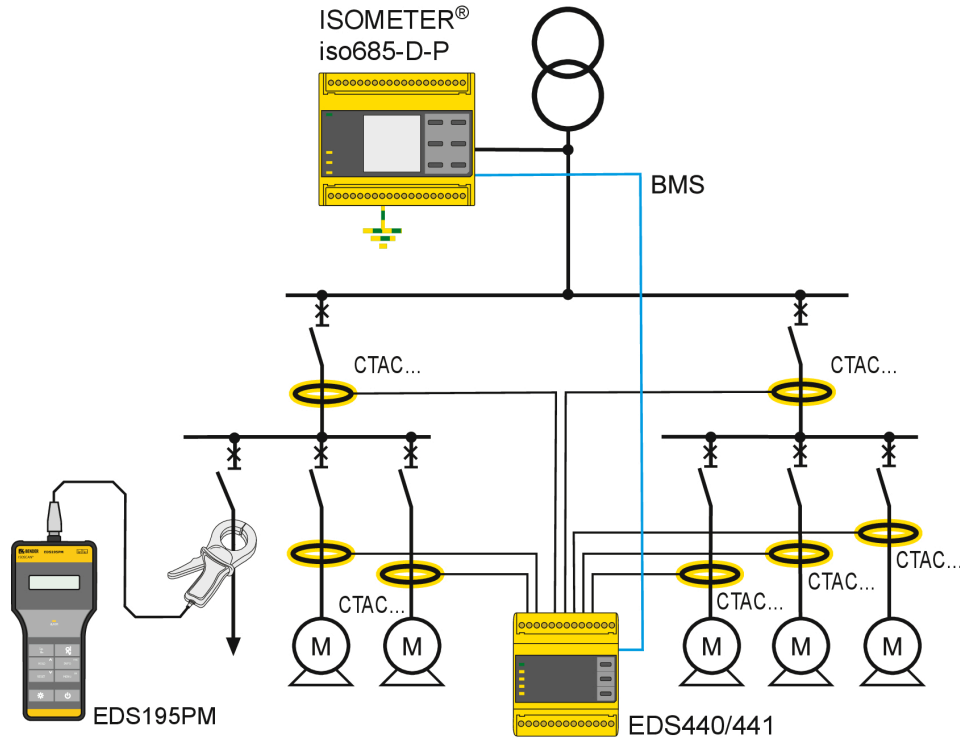

Display and operating elements of the PGH18...

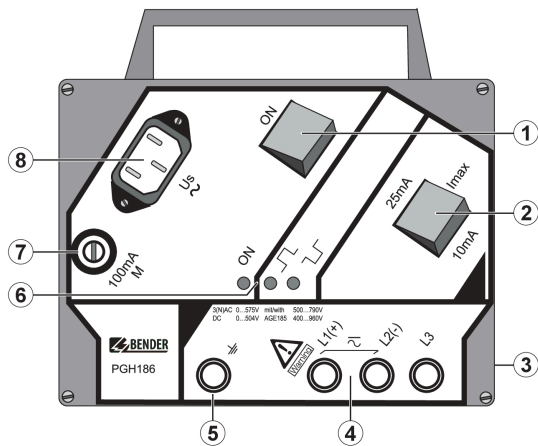

1	ON/OFF switch, switch on or off locating current
2	Changeover switch for maximum locating current values: 25mA / 10mA or 2.5mA / 1mA
3	Rear: Magnetic strip for attachment to metal items (e.g. switch cabinet)
4	3 sockets for coupling to system
5	Socket for PE connection
6	Indicator LEDs ON: Operation LED : positive locating current cycle : negative locating current cycle
7	Fine-wire fuse 100 mA
8	Connector for supply voltage

Display and operating elements of the EDS195P(M)



1	BNC connection for measuring clamp
2	Measuring signal output for connecting to an oscilloscope (EDS195PM only)
3	Micro USB connection for charging the device's rechargeable batteries
4	LC display, illuminated, 3 lines of 16 characters
5	ALARM LED <ul style="list-style-type: none"> flashes if the response value is exceeded lights up continuously when the fault is cleared and the fault memory is activated
6	Control buttons

Control buttons

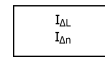

Select the operating mode:

I_{ΔL} Insulation fault location in IT systems (EDS mode)

I_{Δn} Residual current measurement in TN-S systems (RCM mode)

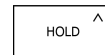

HOLD

Save the measured value.

^ Move up in the menu, increase parameter values.



RESET

Delete fault memory.

v Move down in the menu, reduce parameter values.



Switch display lighting on/off.



Select current transformer:

Display	Device	suitable for
PSA30xx	PSA30... / PSA3165	$I_{Lmax} = 50 \text{ mA}$
CTAF		$I_{Lmax} = 50 \text{ mA}$ $I_{Lmin} = 25 \text{ mA}$
W/WR/WS	W... / WR... / WS...	$I_{Lmax} = 50 \text{ mA}$
PSA33xx	PSA33...	$I_{Lmax} = 5 \text{ mA}$
W/WS-8000	W....-8000 / WS....-8000	$I_{Lmax} = 5 \text{ mA}$
WF	WF...	$I_{\Delta n}$



INFO Display device info:

- device type, date, time, manufacturer
- software version
- Actual response values $I_{\Delta L}$ and $I_{\Delta n}$
- status word (setup status)

ESC Leave a menu function without changing parameters.

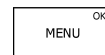

MENU Open the menu.

OK Accept modified parameter values or selected menu items.

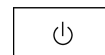

Switch device on/off.

Technical data

Technical data EDS309... system

Valid for PGH18..., EDS195P(M), AGE185

Environment/EMC

EMC	IEC 61326-2-4
Operating temperature	-10...+55 °C

Climatic classes acc. to IEC 60721:

Stationary use (IEC 60721-3-3)	3K22
Transport (IEC 60721-3-2)	2K11
Long-term storage (IEC 60721-3-1)	1K22

Classification of mechanical conditions acc. to IEC 60721:

Stationary use (IEC 60721-3-3)	3M11
Transport (IEC 60721-3-2)	2M4
Long-term storage (IEC 60721-3-1)	1M12

Other

Operating mode	continuous operation
Position in normal use	any
Weight EDS309...	≤ 7000 g
Weight EDS309... with PSA3165	≤ 8500 g
Weight EDS3092	≤ 9000 g
Dimensions, case W × H × D	430 × 340 × 155 mm

Technical data PGH18...

Insulation coordination according to IEC 60664-1 /

IEC 60664-3

Rated voltage	AC 500 V
Rated surge voltage	4 kV
Degree of pollution	3

Nominal system voltage U_n

PGH183	AC 42...460 Hz; 20...265 V DC 20...308 V
PGH185	(3)AC 42...460 Hz; 20...575 V DC 20...504 V
PGH186	(3)AC 42...460 Hz; 0...575 V DC 0...504 V

Supply voltage

Supply voltage U_S	AC 50...60 Hz; 230 V
Operating range of U_S	0.85...1.15 × U_S
Supply voltage U_S version -13	AC 50...60 Hz; 90...132 V
Power consumption	
PGH 183, PGH 185	≤ 3 VA
PGH 186	≤ 6 VA

Locating current

PGH183	selectable: 1 mA / 2.5 mA
PGH185/186	selectable: 10 mA / 25 mA
Test cycle	2 s
Pause duration	4 s

Locating voltage

PGH186	DC 50 V
--------	---------

Other

Degree of protection of built-in components DIN EN 60529 (VDE 0470-1)	IP40
Enclosure material	ABS plastic
Flammability class	UL 94 V-0
Weight	≤ 700 g
Dimensions	160 × 148 × 81 mm

Technical data EDS195P(M)

() * = Factory settings

Insulation coordination according to IEC 60664-1 / IEC 60664-3

Rated voltage	50 V
Rated surge voltage	0.8 kV
Degree of pollution	3

Supply voltage

Power supply U_S	Rechargeable batteries, batteries or USB power supply unit
Rechargeable batteries	3 × NiMH R6 AA – 1.2 V – min. 2000 mAh
Operating time (without display lighting)	≤ 150 h
Charging time	≤ 5 h
Batteries	3 × LR6 AA – 1.5 V
USB power supply unit:	
Primary	100...240 V; 50...60 Hz
Secondary	DC 5 V; ± 10 %
Power consumption	≤ 0.5 W

Measuring circuit, insulation fault location

Nominal system voltage	with uninsulated conductors with measuring clamp up to 600 V
Rated frequency	DC, 42...2000 Hz
Main circuit ($I_{Lmax} = 50$ mA):	
Measuring range	2 mA...50 mA
Measuring clamps	PSA3020, PSA3052, PSA3165
Response sensitivity $I_{\Delta L}$ adjustable	2...10 mA (5 mA)*
Operating uncertainty	±30 % / ±2 mA of nominal value
Control circuit ($I_{Lmax} = 5$ mA):	
Measuring range	0.2...5 mA
Measuring clamps	PSA3320, PSA3352
Response sensitivity $I_{\Delta L}$ adjustable	0.2...1.0 mA (0.5 mA)*
Operating uncertainty 0.2...0.9 mA	±30 % / ±0.2 mA of the nominal value
Operating uncertainty 1...5 mA	±30 % / ±2 mA of the nominal value

Measuring circuit, residual current

Measuring clamps PSA3020, PSA3052, PSA3165:	
Measuring range	5 mA ... 10 A (crest factor up to 3)
Response sensitivity $I_{\Delta n}$ adjustable	10 mA ... 10 A (100 mA)*
Measuring clamps PSA3320, PSA3352:	
Measuring range	2 mA ... 2 A (crest factor up to 3)
Response sensitivity $I_{\Delta n}$ adjustable	5 mA ... 1 A (100 mA)*
Frequency range	42...1000 Hz
Operating uncertainty, 42...60 Hz	±5 %
Operating uncertainty, 61...1000 Hz	±20 %
Hysteresis	20 %
Harmonics, indication can be disabled	1st to 8th harmonic

Inputs

Connection for measuring clamp	BNC socket
Connection for power supply unit (DC 5 V)	µUSB socket

Display

LCD	3 × 16 characters, switchable backlight
LED	Alarm

Other

Degree of protection of built-in components DIN EN 60529 (VDE 0470-1)	IP40
Protective class according to IEC 60947-1, DIN EN 60947-1 (VDE 0660-100)	III
Enclosure material	ABS plastic
Flammability class	UL 94 V-0
Weight	≤350 g
Software version	D399 V2.1
Dimensions W × H × D	84 × 197 × 30 mm

Technical data AGE185
Insulation co-ordination according to 60664-1

Rated insulation voltage	AC 1000 V
Rated impulse voltage	4 kV
Degree of pollution	3
Nominal system voltage U_n	(3)AC 42...460 Hz, 500...790 V DC 400...960 V

Other

Degree of protection of built-in components DIN EN 60529 (VDE 0470-1)	IP30
Connection type/wire	Safety laboratory connectors with green-yellow connection wire 1 mm ²
Weight	≤ 200 g
Dimensions W × H × D	88.5 × 42 × 21 mm

Technical data measuring clamps

Note: The technical data for the CTA-F-set can be found at

<https://www.bender.de/en/service-support/download-area/>

Electrical safety

Standard	IEC 61010-2-030
Degree of pollution	2
System class	III
Operating voltage	600 V
Nominal insulation voltage	AC 600 V CAT III or AC 300 V CAT IV

Transformer ratio

PSA30...	10 A / 10 mA
PSA33...	1 A / 0.1 mA
PSA3165	10 A / 10 mA

Other

Degree of protection of built-in components DIN EN 60529 (VDE 0470-1)	IP40
Protective class according to IEC 60947-1, DIN EN 60947-1 (VDE 0660-100)	III
Measurement output	BNC socket
Dimensions PSA3052/3352	216 × 111 × 45 mm
Dimensions PSA3020/3320	135 × 65 × 30 mm
Dimensions PSA3165	285 × 179 × 45 mm
Permissible cable diameter PSA3052/3352	52 mm
Permissible cable diameter PSA3020/3320	20 mm
Permissible cable diameter PSA3165	115 mm
Weight PSA3052/3352	≤700 g
Weight PSA3020/3320	≤300 g
Weight PSA3165	≤1300 g

Standards and certifications

Observe the applicable national and international standards. The series EDS309... complies with the standards:

- DIN VDE 0100-410 (VDE 0100-410)
Low-voltage electrical installations – Part 4-41: Protection for safety – Protection against electric shock (IEC 60364-4-41, modified);
German version HD 60364-4-41
- DIN EN 61557-9
Electrical safety in low voltage distribution systems up to 1000 V a.c. and 1500 V d.c. – Equipment for testing, measuring or monitoring of protective measures - Part 9: Equipment for insulation fault location in IT systems (IEC 61557-9);
German version EN 61557-9
- DIN EN 61010-1; VDE 0411-1
Safety requirements for electrical equipment for measurement, control and laboratory use – Part 1: General requirements (IEC 61010-1); German version EN 61010-1



Dimension diagrams

PSA3020/3320

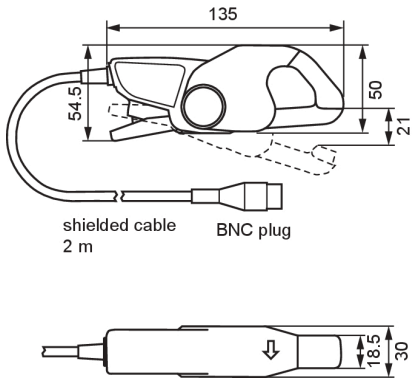

PSA3052/3352

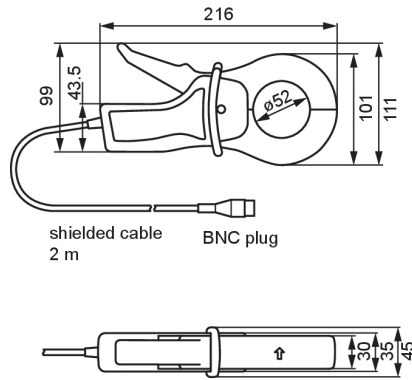

PSA3165

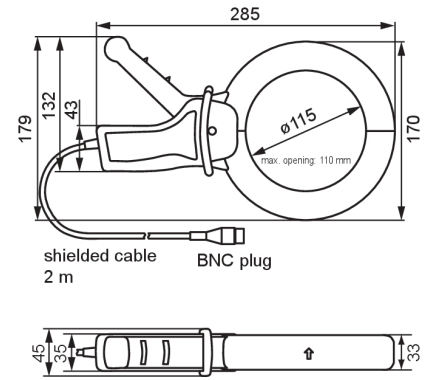

Aluminium case

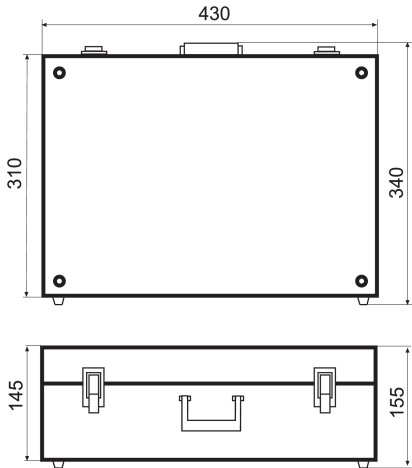

AGE185

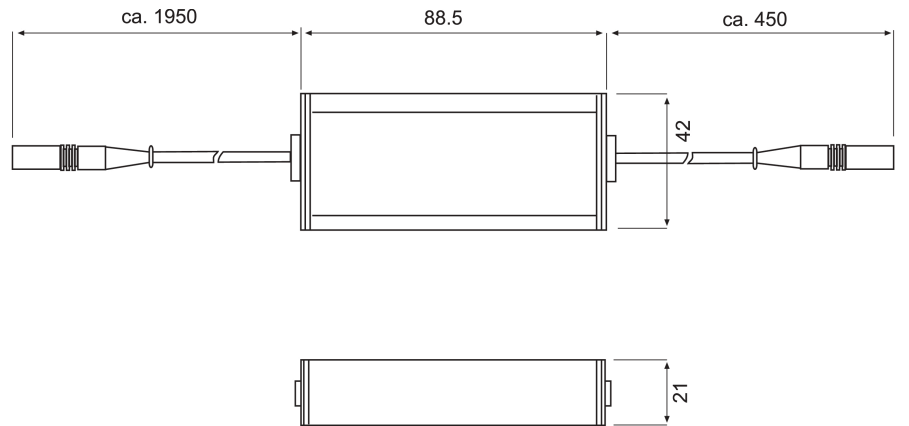

Ordering details
EDS309x

Type	Items supplied*				Supply voltage	Nominal voltage	Art. No.
	Insulation fault locator	Locating current injector	Measuring clamp 20 mm	Measuring clamp 52 mm			
EDS3090	EDS195PM		PSA3020	PSA3052		AC 42...460 Hz, 20...575 V; DC 20...504 V	B91082026
EDS3090PG	EDS195PM	PGH185	PSA3020	PSA3052	AC 50...60 Hz, 230 V		B91082021
EDS3090PG-13	EDS195PM	PGH185-13	PSA3020	PSA3052	AC 50...60 Hz, 90...132 V		B91082022
EDS3091	EDS195PM		PSA3320	PSA3352		AC 42...460 Hz, 20...265 V; DC 20...308 V	B91082027
EDS3091PG	EDS195PM	PGH183	PSA3320	PSA3352	AC 50...60 Hz, 230 V		B91082023
EDS3091PG-13	EDS195PM	PGH185-13	PSA3320	PSA3352	AC 50...60 Hz, 90...132 V		B91082024
EDS3092PG	EDS195PM	PGH183	PSA3320	PSA3352	AC 50...60 Hz, 230 V	AC 42...460 Hz, 20...265 V; DC 20...308 V	B91082030
		PGH185	PSA3020	PSA3052	AC 50...60 Hz, 230 V	AC 42...460 Hz, 20...575 V; DC 20...504 V	
EDS3096PG	EDS195PM	PGH186	PSA3020	PSA3052	AC 50...60 Hz, 230 V	AC 42...460 Hz, 0...575 V; DC 0...504 V	B91082025
EDS3096PG-13	EDS195PM	PGH186-13	PSA3020	PSA3052	AC 50...60 Hz, 90...132 V		B91082029
EDS3096PV	EDS195PM	PGH186	-	2 × PSA3052	AC 50...60 Hz, 230 V		B91082031

* Every EDS309x is supplied with a USB power supply unit and USB cable.



Optional accessories

Type	Description	Supply voltage U_s	Art. No.
AGE185	Coupling device for increasing the voltage range of the PGH185/186	AC 42...460 Hz, 500...790 V; DC 400...960 V	B980305
Adapterkabel BNCPS2	Adapter cable for operating a WF current transformer on the EDS195PM		B91082045
EDS-SET	BNC T-connector and 2 BNC cables for fault location in diode-decoupled systems		B91082007
Plug power supply with USB connector	DC 5 V for external supply of the EDS195PM via μ USB connector		A167054
PSA3165	Clamp 115 mm for EDS3090... and EDS3096...		B980852
CTAF SET	Clamp flexible for insulation fault location and differential method, with CTAF ENCLOSURE, CTAF500 BAND, CTAF1000 BAND, BNC cable, terminal, 2 × spare screws, case Only in combination with EDS195PM		B98080220
CTAF GEHÄUSE	CTAF enclosure as spare part for CTAF SET without BNC cable, with terminal and 2 × spare screws		B98110026
CTAF500 BAND	Band 500 mm as spare part for CTAF SET		B98110027
CTAF1000 BAND	Band 1000 mm as spare part for CTAF SET		B98110028

Device selection for IT systems with integrated equipment for insulation fault location

Type of distribution system	AC, DC, AC/DC (mixed systems)
Application range	Main circuits or Control circuits





ISOMETER® insulation monitoring devices with integrated locating current injector

		
Type	iso685-x-P	isoxx1685xP
Nominal system voltage U_n	AC 0...690 V, DC 0...1000 V	isoLR1685DP: AC 0...690, DC 0...690 V iso1685DP: AC 0...1000 V, DC 0...1500 V
Locating current I_L	1/1.8/2.5/5/10/25/50 mA	1/2.5/5/10/25/50 mA
Response values	1 k Ω ...10 M Ω	isoLR1685DP: 20 Ω ...100 k Ω iso1685DP: 200 Ω ...1 M Ω
LC display	graphic display	graphic display
Alarm relay	2 changeover contacts	3 changeover contacts
Interface/protocol	RS-485 (BS)	RS-485 (BS)
Address range	1...90	1...90

Insulation fault locator

	
Type	EDS195P(M)
LC display	3 x 16 characters
Evaluating current $I_{\#L}$	0.2...50 mA
Response value	0.2...1/2...10 mA selectable



Measuring clamps

Application range	Main circuits			Control circuits	
					
Type	PSA3020	PSA3052	PSA3165 (optional)	PSA3320	PSA3352
20 mm	X			X	
52 mm		X			X
115 mm			X		





Complete systems			
Type	EDS3090		EDS3091
Comprising	Aluminium case, EDS195P(M), PSA3020, PSA3052, power supply unit	Aluminium case, EDS195P(M), PSA3020, PSA3052, power supply unit	Aluminium case, EDS195P(M), PSA3320, PSA3352, power supply unit

Device selection for IT systems without a permanently installed equipment for insulation fault location

Application	Main circuit		Control circuit
	energised	offline	energised

Locating current injector PGH			
			
Nominal system voltage U_n	3AC, AC 20...575 V DC 20...504 V	3AC, AC 0...575 V DC 0...504 V	AC 20...265 V, DC 20...308 V
U_s AC 230 V	PGH185	PGH186	PGH183
U_s AC 90...132 V	PGH185-13	PGH186-13	PGH183-13
Locating current I_L max.	10/25 mA	10/25 mA	1/2.5 mA

Insulation fault locator	
	
Type	EDS195P(M)
LC display	3 x 16 characters
Evaluating current $I_{#L}$	0.2...50 mA
Response value	0.2...1/2...10 mA selectable

Measuring clamps					
					
Type	PSA3020	PSA3052	PSA3165 (optional)	PSA3320	PSA3352
20 mm	x			x	
52 mm		x			x
115 mm			x		

Component list

Components EDS309...

	EDS195PM with accessories							PGH18... with accessories for							Measuring clamps			
Device type	Aluminium case with carrying handle	Operating manual	Insulation fault locator	Clamping connector on 4 mm	Adapter BNC/4mm connector for CT	Adapter BNC-PS2 for WF-CT, optional	Plug power supply for EDS195PM	Locating current injector	Supply cable for PGH18...	Safety measuring cable, black	Safety measuring cable, green/yellow	Safety claw grip, black	Safety claw grip, green/yellow	Coupling device, optional (delivered with EDS3096PV only)	Measuring clamp 20 mm	Measuring clamp 52 mm	Measuring clamp 115 mm, optional	EDS SET, optional
EDS3090	1	1	EDS195PM	1	1	1	1							PSA3020	PSA3052	PSA3165	1	
EDS3090PG	1	1	EDS195PM	1	1	1	1	PGH185	1	3	1	3	1	AGE185	PSA3020	PSA3052	PSA3165	1
EDS3090PG-13	1	1	EDS195PM	1	1	1	1	PGH185-13	1	3	1	3	1	AGE185	PSA3020	PSA3052	PSA3165	1
EDS3091	1	1	EDS195PM	1	1	1	1							PSA3320	PSA3352		1	
EDS3091PG	1	1	EDS195PM	1	1	1	1	PGH183	1	3	1	3	1		PSA3320	PSA3352		1
EDS3091PG-13	1	1	EDS195PM	1	1	1	1	PGH185-13	1	3	1	3	1		PSA3320	PSA3352		1
EDS3092PG	1	1	EDS195PM	1	1	1	1	PGH183 PGH185	2	6	2	6	2		PSA3320 PSA3020	PSA3352 PSA3052		1
EDS3096PG	1	1	EDS195PM	1	1	1	1	PGH186	1	3	1	3	1	AGE185	PSA3020	PSA3052	PSA3165	1
EDS3096PG-13	1	1	EDS195PM	1	1	1	1	PGH186-13	1	3	1	3	1	AGE185	PSA3020	PSA3052	PSA3165	1
EDS3096PV	1	1	EDS195PM	-	-	-	1	PGH186	1	3	1	3	1	AGE185	-	2 × PSA3052	-	-



Bender GmbH & Co. KG

Londorfer Straße 65
35305 Grünberg
Germany

Tel.: +49 6401 807-0
info@bender.de
www.bender.de



© Bender GmbH & Co. KG, Germany
Subject to change!
The specified standards take into account the edition valid until 06.2025 unless otherwise indicated.