

LINETRAXX® CTAC series

Measuring current transformers





measuring current transformers CTAC series

Product description

The highly sensitive CTAC series measuring current transformers in combination with RCM or RCMS series residual current monitors and evaluators convert AC currents into an evaluable measurement signal.

They are also suitable for use in insulation fault location systems for IT systems (EDS). The current transformers measure the locating current generated by a PGH locating current injector or an ISOMETER® iso685. In combination with EDS series insulation fault locators, the locating current is converted into an evaluable measurement signal.

The connection to the respective devices is made via a two-wire cable.

Wiring diagram

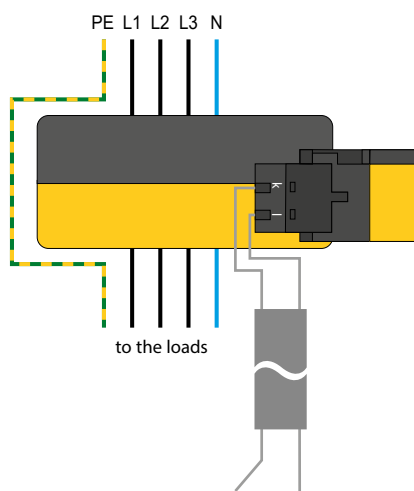

Connection to the respective device k = S1 l = S2

Device features

Measuring current transformers CTAC...

- For RCMS460/490 residual current monitoring systems
- For RCM420 residual current monitors
- For EDS440 and EDS460/490 insulation fault locators in AC and DC systems

Measuring current transformers CTAC.../01

- For EDS441 and EDS461/EDS491 insulation fault locators

Approvals and certifications



Measuring current transformers CTAC...

Connection to the respective residual current monitoring system RCMS, residual current monitors RCM or to insulation fault location systems EDS

Measuring current transformers CTAC.../01

Connection to the respective EDS441, EDS461, EDS491 and insulation fault locator

Ordering information

Mounting	Inside diameter	Type	Art. No.
Mounting brackets, DIN rail	20 mm	CTAC20	B98110005
		CTAC20/01 ¹⁾	B98110006
	35 mm	CTAC35	B98110007
		CTAC35/01 ¹⁾	B98110008
	60 mm	CTAC60	B98110017
		CTAC60/01 ¹⁾	B98110018
Mounting brackets	120 mm	CTAC120	B98110019
	210 mm	CTAC210	B98110020

¹⁾ For EDS441 and EDS461/491 insulation fault locators

Selection list

Type	RCM420	RCMS460 RCMS490	EDS440 EDS460 EDS490	EDS441 EDS461 EDS491	EDS440
CTAC20	■	■	■	–	■
CTAC35	■	■	■	–	■
CTAC60	■	■	■	–	■
CTAC120	■	■	■	–	■
CTAC210	■	■	■	–	■
CTAC20/01	–	–	–	■	–
CTAC35/01	–	–	–	■	–
CTAC60/01	–	–	–	■	–

Accessories

Type designation	Art. No.
Snap-on mounting for CTAC20 and CTAC20/01	B91080111
Snap-on mounting for CTAC35 and CTAC35/01	B91080112

Technical data
Insulation coordination acc. to IEC 60664-1

Rated insulation voltage	800 V
Overvoltage category	III
Rated impulse voltage/pollution degree	8 kV/3

Measuring current transformer circuit CTAC...

Rated primary residual current	10 A
Rated secondary residual current	0.0167 A
Rated transformation ratio K_n	10/0.0167 A
Rated burden	max. 180 Ω
Rated output	0.05 VA
Rated continuous thermal current I_{cth}	30 A
Rated short-time thermal current I_{th}	$60 \times I_{cth} = 2.4 \text{ kA/1 s}$
Rated dynamic current I_{dyn}	$2.5 \times I_{th} = 6.0 \text{ kA/40 ms}$
Rated current I	
CTAC20 at $I_{\Delta n} \geq 30 \text{ mA}$	40 A
CTAC20 at $I_{\Delta n} \geq 300 \text{ mA}$	63 A
CTAC35 at $I_{\Delta n} \geq 30 \text{ mA}$	80 A
CTAC35 at $I_{\Delta n} \geq 300 \text{ mA}$	125 A
CTAC60 at $I_{\Delta n} \geq 30 \text{ mA}$	160 A
CTAC60 at $I_{\Delta n} \geq 300 \text{ mA}$	250 A
CTAC120 at $I_{\Delta n} \geq 100 \text{ mA}$	330 A
CTAC210 at $I_{\Delta n} \geq 300 \text{ mA}$	630 A

Measuring current transformer circuit CTAC.../01

Rated primary residual current	1 A
Rated secondary residual current	0.125 mA
Rated transformation ratio K_n	1 A/0.125 mA
Rated continuous thermal current I_{cth}	6 A
Rated short-time thermal current I_{th}	$60 \times I_{cth} = 0.36 \text{ kA/1 s}$
Rated dynamic current I_{dyn}	$2.5 \times I_{th} = 0.9 \text{ kA/40 ms}$
Rated current I	
CTAC20/01 at $I_{\Delta n} \geq 30 \text{ mA}$	40 A
CTAC20/01 at $I_{\Delta n} \geq 300 \text{ mA}$	63 A
CTAC35/01 at $I_{\Delta n} \geq 30 \text{ mA}$	80 A
CTAC35/01 at $I_{\Delta n} \geq 300 \text{ mA}$	125 A
CTAC60/01 at $I_{\Delta n} \geq 30 \text{ mA}$	160 A
CTAC60/01 at $I_{\Delta n} \geq 300 \text{ mA}$	250 A

Environment

Operating temperature	-25...+70 °C
-----------------------	--------------

Climatic class acc. to IEC 60721

Stationary use (IEC 60721-3-3)	3K5 (except condensation and formation of ice)
Transport (IEC 60721-3-2)	2K11 (except condensation and formation of ice)
Long-time storage (IEC 60721-3-1)	1K22 (except condensation and formation of ice)

Classification of mechanical conditions IEC 60721

Stationary use (IEC 60721-3-3)	3M4
Transport (IEC 60721-3-2)	2M4
Long-time storage (IEC 60721-3-1)	1M12

Connection

Terminal type	MSTB 2,5/ 2-ST-5,08
Manufacturer	Phoenix Contact Connection
Connection type	screw type terminal
The connection conditions of the manufacturer apply.	
Connection properties	
rigid	0,2...2,5 mm ² (AWG24...12)
flexible	0,2...2,5 mm ² (AWG 24...12)
Stripping length	7 mm

Connection EDS, RCM(S) measuring current transformers

Single wire $\geq 0.75 \text{ mm}^2$	0...1 m
Single wire, twisted $\geq 0.75 \text{ mm}^2$	0...10 m
Shielded cable $\geq 0.5 \text{ mm}^2$	0...40 m
Shielded cable (shield on one side connected to L-conductor, not connected to earth)	
	recommended: J-Y(St)Y min. 2x0.8

Mounting

Screw Type	
CTAC20...60(/01)	DIN EN ISO 7045 - M5x
CTAC120...210	DIN EN ISO 7045 - M6
Washer type	
CTAC20...60(/01)	DIN EN ISO 7089/7090 - 5
CTAC120...210	DIN EN ISO 7089/7090 - 6
Tightening torque	
CTAC20...35 (/01)	0,6 Nm
CTAC60(/01)...210	1 Nm

Other

Degree of protection, internal components (DIN EN 60529)	IP40
Degree of protection, terminals (IEC 60529)	IP20
Flammability class	UL94 V-0
Documentation number	D00386

Dimension diagrams

CTAC20(/01)/CTAC35(/01)

CTAC60(/01)

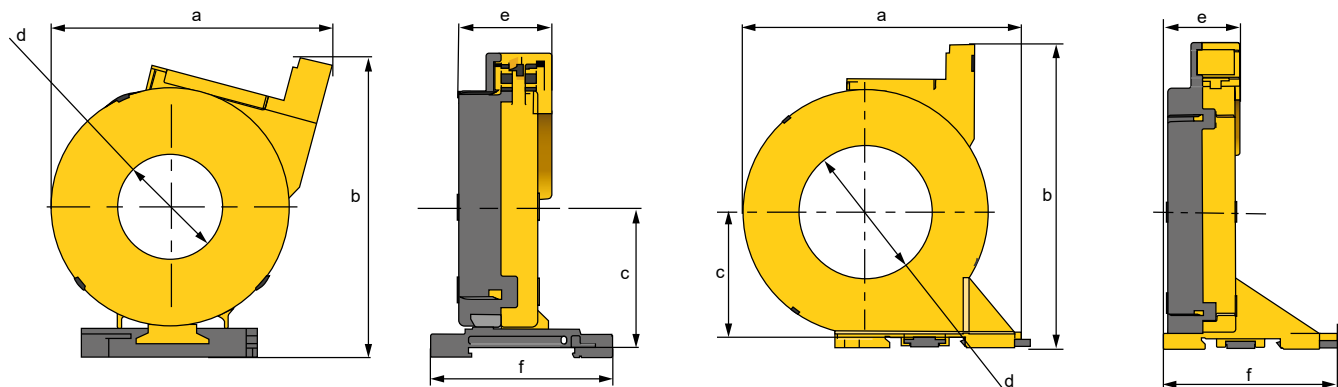

CTAC120/CTAC210

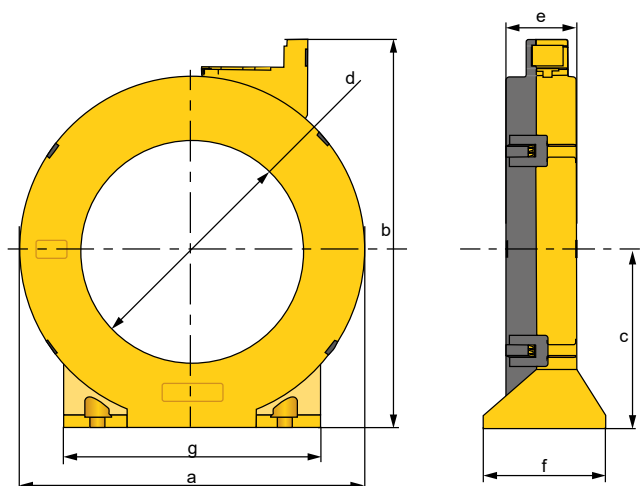

Dimensions (mm)							
Type	a	b	c	d	e	f	g
CTAC20(/01)	75	82	37	∅ 20	32	60	
CTAC35(/01)	94	100	47	∅ 35	30	61	
CTAC60(/01)	126	137	57	∅ 60	33	78	
CTAC120	188	211	96	∅ 120	38	66	139
CTAC210	302	324	153	∅ 210	40	74	277

Tolerance: ±0,5 mm

Mountings

CTAC20(/01)/CTAC35(/01)

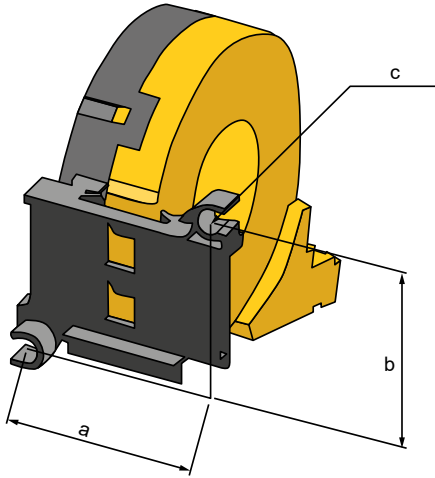

CTAC60(/01)

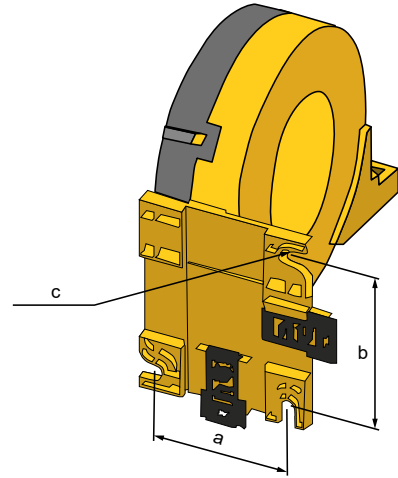

CTAC120/CTAC210

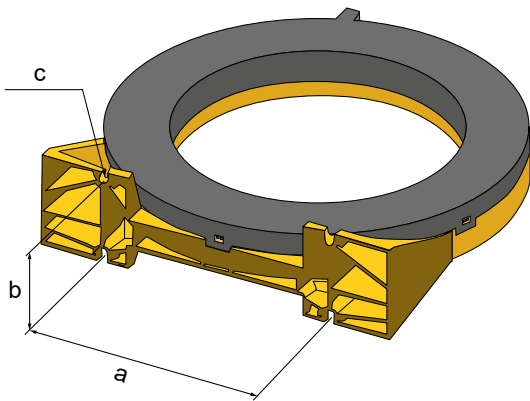

Dimensions (mm) (mm)			
Type	a	b	c
CTAC20(/01)	31,4	49	2 x Ø 5,5
CTAC35(/01)	49,8	42	2 x Ø 5,5
CTAC60(/01)	56	66	3 x Ø 6,5
CTAC120	103	51	4 x Ø 6,5
CTAC210	180	59	4 x Ø 5,5

Installation instructions

- Do not route any shielded cables through the measuring current transformer.
- Existing protective conductors and low-resistance conductor loops must not be routed through the measuring current transformer!

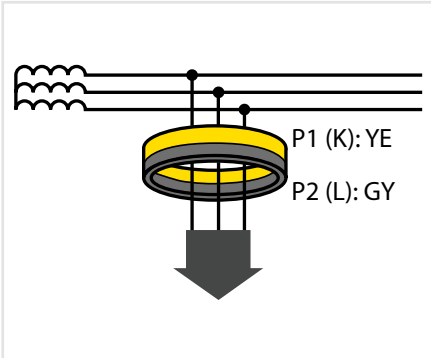

The direction in which the cables are routed through the measuring current transformer must be observed.

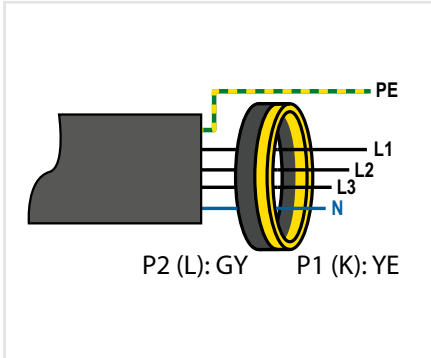

Never route an existing protective conductor through the measuring current transformer.

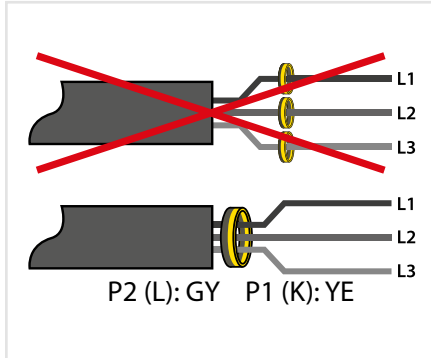

All current-carrying cables must be routed together through the measuring current transformer.

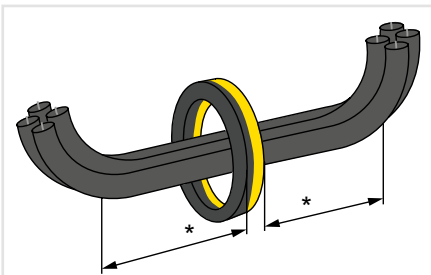

* Distance to 90° angle:
2x external diameter of the current transformer

The primary conductors may only be bent from the specified minimum distance. The minimum bending radius specified by the manufacturers must be observed.

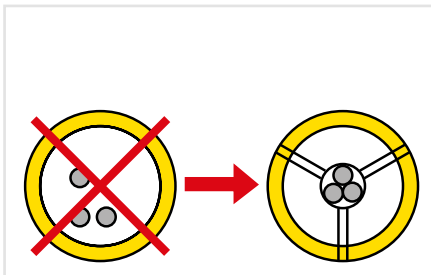

The cables must be centred in the measuring current transformer.

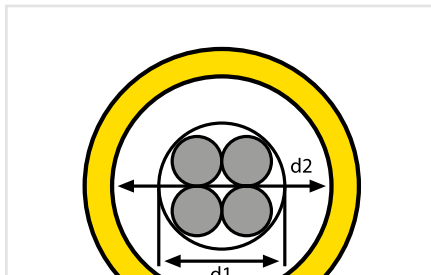

Internal diameter of the measuring current transformer $d2 \geq 2 \times d1$ (cable diameter)



Bender GmbH & Co. KG
 Postfach 1161 • 35301 Grünberg • Germany
 Londorfer Straße 65 • 35305 Grünberg • Germany
 Tel.: +49 6401 807-0 • Fax: +49 6401 807-259
 E-Mail: info@bender.de • www.bender.de



BENDER Group